



An Oshkosh Corporation Company

---

# ***Operation and Safety Manual***

*Original Instructions - Keep this manual with the machine at all times.*

***Boom Lift Models***

***600A***

***600AJ***

***S/N 0300177361***

***to Present***



**3121615**  
*October 1, 2014*

**NOTE:** *This manual also applies to a machine with the following  
Serial Number: 0300176207.*

## **FOREWORD**

This manual is a very important tool! Keep it with the machine at all times.

The purpose of this manual is to provide owners, users, operators, lessors, and lessees with the precautions and operating procedures essential for the safe and proper machine operation for its intended purpose.

Due to continuous product improvements, JLG Industries, Inc. reserves the right to make specification changes without prior notification. Contact JLG Industries, Inc. for updated information.

## **SAFETY ALERT SYMBOLS AND SAFETY SIGNAL WORDS**



This is the Safety Alert Symbol. It is used to alert you to the potential personal injury hazards. Obey all safety messages that follow this symbol to avoid possible injury or death

### **⚠ DANGER**

INDICATES AN IMMINENTLY HAZARDOUS SITUATION. IF NOT AVOIDED, WILL RESULT IN SERIOUS INJURY OR DEATH. THIS DECAL WILL HAVE A RED BACKGROUND.

### **⚠ WARNING**

INDICATES A POTENTIALLY HAZARDOUS SITUATION. IF NOT AVOIDED, COULD RESULT IN SERIOUS INJURY OR DEATH. THIS DECAL WILL HAVE AN ORANGE BACKGROUND.

### **⚠ CAUTION**

INDICATES A POTENTIALLY HAZARDOUS SITUATION. IF NOT AVOIDED, MAY RESULT IN MINOR OR MODERATE INJURY. IT MAY ALSO ALERT AGAINST UNSAFE PRACTICES. THIS DECAL WILL HAVE A YELLOW BACKGROUND.

### **NOTICE**

INDICATES INFORMATION OR A COMPANY POLICY THAT RELATES DIRECTLY OR INDIRECTLY TO THE SAFETY OF PERSONNEL OR PROTECTION OF PROPERTY.

**⚠ WARNING**

**THIS PRODUCT MUST COMPLY WITH ALL SAFETY RELATED BULLETINS. CONTACT JLG INDUSTRIES, INC. OR THE LOCAL AUTHORIZED JLG REPRESENTATIVE FOR INFORMATION REGARDING SAFETY-RELATED BULLETINS WHICH MAY HAVE BEEN ISSUED FOR THIS PRODUCT.**

**NOTICE**

**JLG INDUSTRIES, INC. SENDS SAFETY RELATED BULLETINS TO THE OWNER OF RECORD OF THIS MACHINE. CONTACT JLG INDUSTRIES, INC. TO ENSURE THAT THE CURRENT OWNER RECORDS ARE UPDATED AND ACCURATE.**

**NOTICE**

**JLG INDUSTRIES, INC. MUST BE NOTIFIED IMMEDIATELY IN ALL INSTANCES WHERE JLG PRODUCTS HAVE BEEN INVOLVED IN AN ACCIDENT INVOLVING BODILY INJURY OR DEATH OF PERSONNEL OR WHEN SUBSTANTIAL DAMAGE HAS OCCURRED TO PERSONAL PROPERTY OR THE JLG PRODUCT.**

**For:**

- Accident Reporting
- Product Safety Publications
- Current Owner Updates
- Questions Regarding Product Safety
- Standards and Regulations Compliance Information
- Questions Regarding Special Product Applications
- Questions Regarding Product Modifications

**Contact:**

Product Safety and Reliability Department  
JLG Industries, Inc.  
13224 Fountainhead Plaza  
Hagerstown, MD 21742  
USA

or Your Local JLG Office  
(See addresses on inside of manual cover)

**In USA:**

Toll Free: 877-JLG-SAFE (877-554-7233)

**Outside USA:**

Phone: 240-420-2661  
Fax: 301-745-3713  
E-mail: ProductSafety@JLG.com

## **REVISION LOG**

Original Issue	- November 6, 2013
Revised	- January 1, 2014
Revised	- July 4, 2014
Revised	- October 1, 2014

<b>SECTION - PARAGRAPH, SUBJECT</b>	<b>PAGE</b>
<b>SECTION - 1 - SAFETY PRECAUTIONS</b>	
1.1 GENERAL .....	1-1
1.2 PRE-OPERATION .....	1-1
Operator Training and Knowledge .....	1-1
Workplace Inspection .....	1-2
Machine Inspection .....	1-3
1.3 OPERATION .....	1-3
General .....	1-3
Trip and Fall Hazards .....	1-4
Electrocution Hazards .....	1-5
Tipping Hazards .....	1-7
Crushing and Collision Hazards .....	1-10
1.4 TOWING, LIFTING, AND HAULING .....	1-11
1.5 MAINTENANCE .....	1-11
Maintenance Hazards .....	1-11
Battery Hazards .....	1-13
<b>SECTION - 2 - USER RESPONSIBILITIES, MACHINE PREPARATION, AND INSPECTION</b>	
2.1 PERSONNEL TRAINING .....	2-1
Operator Training .....	2-1
Training Supervision .....	2-1
Operator Responsibility .....	2-1
2.2 PREPARATION, INSPECTION, AND MAINTENANCE .....	2-2
Pre-Start Inspection .....	2-4
Function Check .....	2-5

<b>SECTION - PARAGRAPH, SUBJECT</b>	<b>PAGE</b>
2.3 LIMIT SWITCH FUNCTIONAL CHECK .....	2-6
General .....	2-14
<b>SECTION - 3 - MACHINE CONTROLS AND INDICATORS</b>	
3.1 GENERAL .....	3-1
3.2 CONTROLS AND INDICATORS .....	3-1
Ground Control Station .....	3-2
Ground Control Indicator Panel .....	3-8
Platform Station .....	3-10
Platform Control Indicator Panel .....	3-16
<b>SECTION - 4 - MACHINE OPERATION</b>	
4.1 DESCRIPTION .....	4-1
4.2 OPERATING CHARACTERISTICS AND LIMITATIONS .....	4-1
Capacities .....	4-1
Stability .....	4-2
4.3 ENGINE OPERATION .....	4-4
Starting Procedure .....	4-4
Shutdown Procedure .....	4-5
Fuel Reserve / Shut-Off System .....	4-5
4.4 TRAVELING (DRIVING) .....	4-6
Traveling Forward and Reverse .....	4-8
4.5 STEERING .....	4-9
4.6 PLATFORM .....	4-9
Platform Level Adjustment .....	4-9
Platform Rotation .....	4-9

## TABLE OF CONTENTS

---

SECTION - PARAGRAPH, SUBJECT	PAGE	SECTION - PARAGRAPH, SUBJECT	PAGE
4.7 BOOM.....	4-10	5.4 EMERGENCY TOWING PROCEDURES.....	5-2
Swinging the Boom .....	4-10		
Raising and Lowering the Tower Boom.....	4-11		
Raising and Lowering the Main Boom .....	4-12		
Telescoping the Main Boom .....	4-12		
4.8 RE-SYNCHRONIZE THE LOWER LIFT CYLINDER .....	4-12		
Level Override Valve.....	4-12		
4.9 SHUT DOWN AND PARK.....	4-15		
4.10 OSCILLATING AXLE LOCKOUT TEST (IF EQUIPPED) ...	4-15		
4.11 STEER/TOW SELECTOR (IF EQUIPPED).....	4-15		
4.12 TOWING (IF EQUIPPED) .....	4-16		
4.13 AUXILIARY POWER.....	4-19		
Activating from the Platform Control Station .....	4-19		
Activating from the Ground Control Station .....	4-19		
4.14 DUAL FUEL SYSTEM (GAS ENGINE ONLY) .....	4-20		
Changing From Gasoline to LP Gas.....	4-20		
Changing From LP Gas to Gasoline.....	4-20		
4.15 TIE DOWN AND LIFTING.....	4-21		
<b>SECTION - 5 - EMERGENCY PROCEDURES</b>		<b>SECTION - 6 - GENERAL SPECIFICATIONS &amp; OPERATOR MAINTENANCE</b>	
5.1 GENERAL.....	5-1	6.1 INTRODUCTION.....	6-1
5.2 INCIDENT NOTIFICATION.....	5-1	6.2 OPERATING SPECIFICATIONS.....	6-1
5.3 EMERGENCY OPERATION.....	5-1	Dimensional Data .....	6-2
Operator Unable to Control Machine.....	5-1	Capacities.....	6-3
Platform or Boom Caught Overhead .....	5-2	Engine Data.....	6-3
		Tires .....	6-5
		Hydraulic Oil .....	6-5
		Critical Stability Weights.....	6-9
		Serial Number Locations.....	6-10
		6.3 OPERATOR MAINTENANCE.....	6-18
		6.4 TIRES & WHEELS .....	6-27
		Tire Inflation .....	6-27
		Tire Damage .....	6-27
		Tire Replacement.....	6-28
		Wheel Replacement .....	6-28
		Wheel Installation .....	6-28
		6.5 OSCILLATING AXLE LOCKOUT TEST (IF EQUIPPED) ...	6-30
		6.6 PROPANE FUEL FILTER REPLACEMENT.....	6-31
		Removal .....	6-31
		Installation.....	6-32



<b>SECTION - PARAGRAPH, SUBJECT</b>	<b>PAGE</b>	<b>SECTION - PARAGRAPH, SUBJECT</b>	<b>PAGE</b>
6.7 PROPANE FUEL SYSTEM PRESSURE RELIEF .....	6-32		
6.8 SUPPLEMENTAL INFORMATION .....	6-33		

**SECTION - 7 - INSPECTION AND REPAIR LOG**

**TABLE OF CONTENTS**

---

**SECTION - PARAGRAPH, SUBJECT**

**PAGE**

**SECTION - PARAGRAPH, SUBJECT**

**PAGE**

**This Page Left Blank Intentionally.**

<b>FIGURE NUMBER - TITLE</b>	<b>PAGE</b>	<b>FIGURE NUMBER - TITLE</b>	<b>PAGE</b>
2-1. Basic Nomenclature - 600A .....	2-9	6-1. Serial Number Locations .....	6-10
2-2. Basic Nomenclature - 600AJ .....	2-10	6-2. Engine Operating Temperature Specifications - Deutz - Sheet 1 of 2 .....	6-11
2-3. Daily Walk-Around Inspection Diagram - Deutz D2011L04 .....	2-11	6-3. Engine Operating Temperature Specifications - Deutz - Sheet 2 of 2 .....	6-12
2-4. Daily Walk-Around Inspection Diagram - Deutz TD2.9 .....	2-12	6-4. Engine Operating Temperature Specifications - GM - Sheet 1 of 2 .....	6-13
2-5. Daily Walk-Around Inspection Diagram - GM 3.0L ....	2-13	6-5. Engine Operating Temperature Specifications - GM - Sheet 2 of 2 .....	6-14
2-6. Daily Walk-Around Inspection Points - Sheet 1 of 2 ...	2-14	6-6. Operator Maintenance & Lubrication Diagram - Deutz D2011L04 .....	6-15
2-7. Daily Walk-Around Inspection Points - Sheet 2 of 2 ...	2-15	6-7. Operator Maintenance & Lubrication Diagram - Deutz TD2.9 .....	6-16
3-1. Ground Control Station - 600AJ .....	3-3	6-8. Operator Maintenance & Lubrication Diagram - GM 3.0L .....	6-17
3-2. Ground Control Station - 600A .....	3-4	6-9. Deutz 2011 Engine Dipstick .....	6-23
3-3. Ground Control Indicator Panel .....	3-9	6-10. Filter Lock Assembly .....	6-31
3-4. Platform Control Console .....	3-12		
3-5. Platform Control Indicator Panel .....	3-17		
4-1. Position of Least Backward Stability .....	4-2		
4-2. Position of Least Forward Stability .....	4-3		
4-3. Grade and Sideslope .....	4-7		
4-4. Boom Upright Positioning - Sheet 1 of 2 .....	4-13		
4-5. Boom Upright Positioning - Sheet 2 of 2 .....	4-14		
4-6. Towbar Connecting Points .....	4-17		
4-7. Drive Disconnect Hub .....	4-18		
4-8. Lifting Chart .....	4-22		
4-9. 600A & 600AJ Decal Installation - Sheet 1 of 4 .....	4-23		
4-10. 600A & 600AJ Decal Installation - Sheet 2 of 4 .....	4-24		
4-11. 600A & 600AJ Decal Installation - Sheet 3 of 4 .....	4-25		
4-12. 600A & 600AJ Decal Installation - Sheet 4 of 4 .....	4-26		

***LIST OF FIGURES***

---

**FIGURE NUMBER - TITLE**

**PAGE**

**FIGURE NUMBER - TITLE**

**PAGE**

**This Page Left Blank Intentionally.**

<b>TABLE NUMBER - TITLE</b>	<b>PAGE</b>	<b>TABLE NUMBER - TITLE</b>	<b>PAGE</b>
1-1	Minimum Approach Distances (M.A.D.)	1-6	
1-2	Beaufort Scale (For Reference Only)	1-9	
2-1	Inspection and Maintenance Table	2-3	
4-1	600A Decal Legend	4-27	
4-2	600AJ Decal Legend	4-31	
6-1	Operating Specifications	6-1	
6-2	Dimensional Data	6-2	
6-3	Capacities	6-3	
6-4	Deutz D2011L04 Specifications	6-3	
6-5	Deutz TD 2.9 Specifications	6-4	
6-6	GM 3.0L	6-4	
6-7	Tire Specifications	6-5	
6-8	Hydraulic Oil	6-5	
6-9	Mobilfluid 424 Specs	6-6	
6-10	Mobil DTE 13M Specs	6-6	
6-11	Mobil EAL H 46 Specs	6-7	
6-12	Exxon Univis HVI 26 Specs	6-7	
6-13	Mobil EAL 224H Specs	6-8	
6-14	Quintolubric 888-46	6-8	
6-15	Critical Stability Weights	6-9	
6-16	Lubrication Specifications	6-18	
6-17	Wheel Torque Chart	6-29	
7-1	Inspection and Repair Log	7-1	

***LIST OF TABLES***

---

**TABLE NUMBER - TITLE**

**PAGE**

**TABLE NUMBER - TITLE**

**PAGE**

**This Page Left Blank Intentionally.**

## SECTION 1. SAFETY PRECAUTIONS

### 1.1 GENERAL

This section outlines the necessary precautions for proper and safe machine usage and maintenance. It is mandatory that a daily routine is established based on the content of this manual to promote proper machine usage. A maintenance program, using the information provided in this manual and the Service and Maintenance Manual, must also be established by a qualified person and must be followed to ensure that the machine is safe to operate.

The owner/user/operator/lessor/lessee of the machine must not accept operating responsibility until this manual has been read, training is accomplished, and operation of the machine has been completed under the supervision of an experienced and qualified operator.

This section contains the responsibilities of the owner, user, operator, lessor, and lessee concerning safety, training, inspection, maintenance, application, and operation. If there are any questions with regard to safety, training, inspection, maintenance, application, and operation, please contact JLG Industries, Inc. ("JLG").

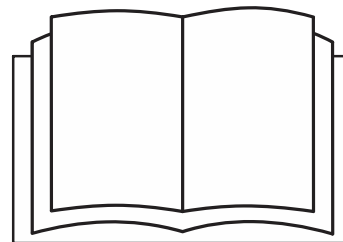
### WARNING

**FAILURE TO COMPLY WITH THE SAFETY PRECAUTIONS LISTED IN THIS MANUAL COULD RESULT IN MACHINE DAMAGE, PROPERTY DAMAGE, PERSONAL INJURY OR DEATH.**

### 1.2 PRE-OPERATION

#### Operator Training and Knowledge

- The Operation and Safety Manual must be read and understood in its entirety before operating the machine. For clarification, questions, or additional information regarding any portions of this manual, contact JLG Industries, Inc.



## **SECTION 1 - SAFETY PRECAUTIONS**

---

- An operator must not accept operating responsibilities until adequate training has been given by competent and authorized persons.
- Allow only those authorized and qualified personnel to operate the machine who have demonstrated that they understand the safe and proper operation and maintenance of the unit.
- Read, understand, and obey all DANGERS, WARNINGS, CAUTIONS, and operating instructions on the machine and in this manual.
- Ensure that the machine is to be used in a manner which is within the scope of its intended application as determined by JLG.
- All operating personnel must be familiar with the emergency controls and emergency operation of the machine as specified in this manual.
- Read, understand, and obey all applicable employer, local, and governmental regulations as they pertain to your utilization and application of the machine.

### **Workplace Inspection**

- Precautions to avoid all hazards in the work area must be taken by the user before and during operation of the machine.
- Do not operate or raise the platform from a position on trucks, trailers, railway cars, floating vessels, scaffolds or other equipment unless the application is approved in writing by JLG.
- Before operation, check work area for overhead hazards such as electric lines, bridge cranes, and other potential overhead obstructions.
- Check operating surfaces for holes, bumps, drop-offs, obstructions, debris, concealed holes, and other potential hazards.
- Check the work area for hazardous locations. Do not operate the machine in hazardous environments unless approved for that purpose by JLG.
- Ensure that the ground conditions are adequate to support the maximum tire load indicated on the tire load decals located on the chassis adjacent to each wheel. Do not travel on unsupported surfaces.



## **Machine Inspection**

- Do not operate this machine until the inspections and functional checks as specified in Section 2 of this manual have been performed.
- Do not operate this machine until it has been serviced and maintained according to the maintenance and inspection requirements as specified in the machine's Service and Maintenance Manual.
- Ensure all safety devices are operating properly. Modification of these devices is a safety violation.

### **WARNING**

**MODIFICATION OR ALTERATION OF AN AERIAL WORK PLATFORM SHALL BE MADE ONLY WITH PRIOR WRITTEN PERMISSION FROM THE MANUFACTURER.**

- Do not operate any machine on which the safety or instruction placards or decals are missing or illegible.
- Check the machine for modifications to original components. Ensure that any modifications have been approved by JLG.
- Avoid accumulation of debris on platform floor. Keep mud, oil, grease, and other slippery substances from footwear and platform floor.

## **1.3 OPERATION**

### **General**

- Machine operation requires your full attention. Bring the machine to a full stop before using any device, i.e. cell phones, two-way radios, etc. that will distract your attention from safely operating the machine.
- Do not use the machine for any purpose other than positioning personnel, their tools, and equipment.
- Before operation, the user must be familiar with the machine capabilities and operating characteristics of all functions.
- Never operate a malfunctioning machine. If a malfunction occurs, shut down the machine. Remove the unit from service and notify the proper authorities.
- Do not remove, modify, or disable any safety devices.
- Never slam a control switch or lever through neutral to an opposite direction. Always return switch to neutral and stop before moving the switch to the next function. Operate controls with slow and even pressure.
- Do not allow personnel to tamper with or operate the machine from the ground with personnel in the platform, except in an emergency.

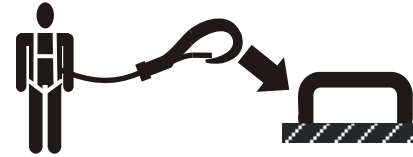
## SECTION 1 - SAFETY PRECAUTIONS

---

- Do not carry materials directly on platform railing unless approved by JLG.
- When two or more persons are in the platform, the operator shall be responsible for all machine operations.
- Always ensure that power tools are properly stowed and never left hanging by their cord from the platform work area.
- When driving, always position boom over rear axle in line with the direction of travel. Remember, if boom is over the front axle, steer and drive functions will be reversed.
- Do not assist a stuck or disabled machine by pushing or pulling except by pulling at the chassis tie-down lugs.
- Fully lower platform and shut off all power before leaving machine.
- Remove all rings, watches, and jewelry when operating machine. Do not wear loose fitting clothing or long hair unrestrained which may become caught or entangled in equipment.
- Persons under the influence of drugs or alcohol or who are subject to seizures, dizziness or loss of physical control must not operate this machine.

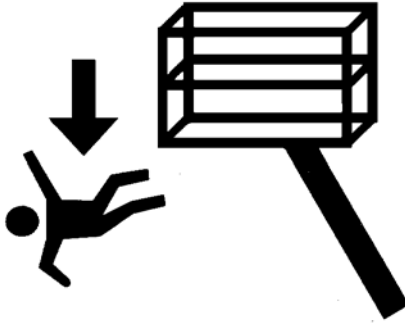
### Trip and Fall Hazards

- During operation, occupants in the platform must wear a full body harness with a lanyard attached to an authorized lanyard anchorage point. Attach only one (1) lanyard per lanyard anchorage point..



- Enter and exit only through gate area. Use extreme caution when entering or leaving platform. Ensure that the platform assembly is fully lowered. Face the machine when entering or leaving the platform. Always maintain “three point contact” with the machine, using two hands and one foot or two feet and one hand at all times during entry and exit.

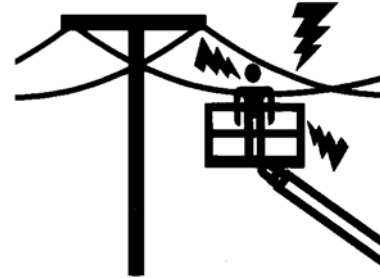
- Before operating the machine, make sure all gates are closed and fastened in their proper position.



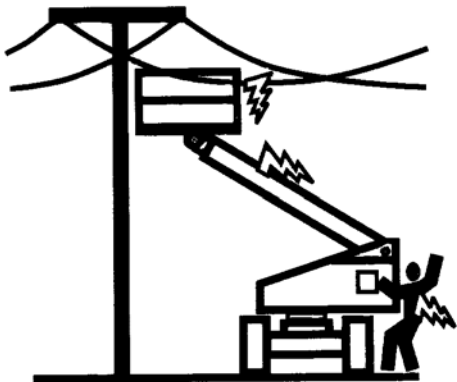
- Keep both feet firmly positioned on the platform floor at all times. Never position ladders, boxes, steps, planks, or similar items on unit to provide additional reach for any purpose.
- Keep oil, mud, and slippery substances cleaned from footwear and the platform floor.

**Electrocution Hazards**

- This machine is not insulated and does not provide protection from contact or proximity to electrical current.



## SECTION 1 - SAFETY PRECAUTIONS



- Maintain distance from electrical lines, apparatus, or any energized (exposed or insulated) parts according to the Minimum Approach Distance (MAD) as shown in Table 1-1.
- Allow for machine movement and electrical line swaying.

**Table 1-1. Minimum Approach Distances (M.A.D.)**

<b>Voltage Range (Phase to Phase)</b>	<b>MINIMUM APPROACH DISTANCE in Feet (Meters)</b>
0 to 50 KV	10 (3)
Over 50KV to 200 KV	15 (5)
Over 200 KV to 350 KV	20 (6)
Over 350 KV to 500 KV	25 (8)
Over 500 KV to 750 KV	35 (11)
Over 750 KV to 1000 KV	45 (14)

**NOTE:** *This requirement shall apply except where employer, local or governmental regulations are more stringent.*

- Maintain a clearance of at least 10 ft. (3m) between any part of the machine and its occupants, their tools, and their equipment from any electrical line or apparatus carrying up to 50,000 volts. One foot additional clearance is required for every additional 30,000 volts or less.

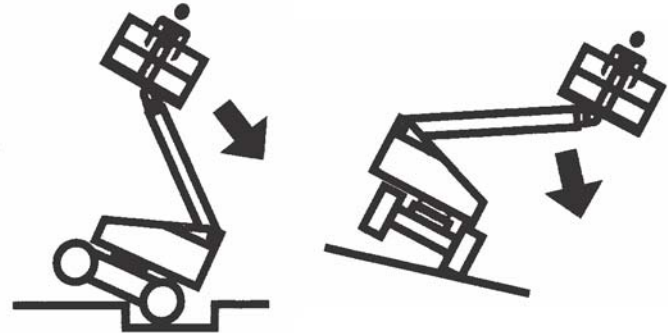
- The minimum approach distance may be reduced if insulating barriers are installed to prevent contact, and the barriers are rated for the voltage of the line being guarded. These barriers shall not be part of (or attached to) the machine. The minimum approach distance shall be reduced to a distance within the designed working dimensions of the insulating barrier. This determination shall be made by a qualified person in accordance with the employer, local, or governmental requirements for work practices near energized equipment

**⚠ DANGER**

**DO NOT MANEUVER MACHINE OR PERSONNEL INSIDE PROHIBITED ZONE (MAD). ASSUME ALL ELECTRICAL PARTS AND WIRING ARE ENERGIZED UNLESS KNOWN OTHERWISE.**

**Tipping Hazards**

- The user must be familiar with the surface before driving. Do not exceed the allowable sideslope and grade while driving.



- Do not elevate platform or drive with platform elevated while on or near a sloping, uneven, or soft surface. Ensure machine is positioned on a firm, level and smooth surface before elevating platform or driving with the platform in the elevated position.
- Before driving on floors, bridges, trucks, and other surfaces, check allowable capacity of the surfaces.

## **SECTION 1 - SAFETY PRECAUTIONS**

---

- Never exceed the maximum work load as specified on the platform. Keep all loads within the confines of the platform, unless authorized by JLG.
- Keep the chassis of the machine a minimum of 2 ft. (0.6m) from holes, bumps, drop-offs, obstructions, debris, concealed holes, and other potential hazards at the ground level.
- Do not push or pull any object with the boom.
- Never attempt to use the machine as a crane. Do not tie-off machine to any adjacent structure. Never attach wire, cable, or any similar items to platform.
- Do not operate the machine when wind conditions exceed 28 mph (12.5 m/s). Refer to Table 1-2, Beaufort Scale (For Reference Only).
- Do not increase the surface area of the platform or the load. Increase of the area exposed to the wind will decrease stability.
- Do not increase the platform size with unauthorized deck extensions or attachments.
- If boom assembly or platform is in a position that one or more wheels are off the ground, all persons must be removed before attempting to stabilize the machine. Use cranes, forklift trucks, or other appropriate equipment to stabilize machine.

**NOTICE**

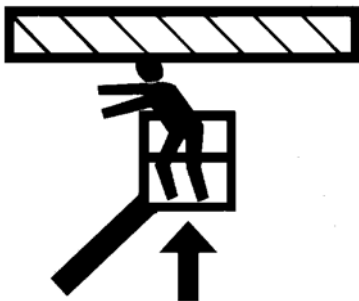
DO NOT OPERATE THE MACHINE WHEN WIND CONDITIONS EXCEED 28 MPH (12.5 M/S).

**Table 1-2. Beaufort Scale (For Reference Only)**

Beaufort Number	Wind Speed		Description	Land Conditions
	mph	m/s		
0	0	0-0.2	Calm	Calm. Smoke rises vertically
1	1-3	0.3-1.5	Light air	Wind motion visible in smoke
2	4-7	1.6-3.3	Light breeze	Wind felt on exposed skin. Leaves rustle
3	8-12	3.4-5.4	Gentle breeze	Leaves and smaller twigs in constant motion
4	13-18	5.5-7.9	Moderate breeze	Dust and loose paper raised. Small branches begin to move.
5	19-24	8.0-10.7	Fresh breeze	Smaller trees sway.
6	25-31	10.8-13.8	Strong breeze	Large branches in motion. Flags waving near horizontal. Umbrella use becomes difficult.
7	32-38	13.9-17.1	Near Gale/Moderate Gale	Whole trees in motion. Effort needed to walk against the wind.
8	39-46	17.2-20.7	Fresh Gale	Twigs broken from trees. Cars veer on road.
9	47-54	20.8-24.4	Strong Gale	Light structure damage.

### Crushing and Collision Hazards

- Approved head gear must be worn by all operating and ground personnel.
- Check work area for clearances overhead, on sides, and bottom of platform when lifting or lowering platform, and driving.



- During operation, keep all body parts inside platform railing.
- Use the boom functions, not the drive function, to position the platform close to obstacles.
- Always post a lookout when driving in areas where vision is obstructed.

- Keep non-operating personnel at least 6 ft. (1.8m) away from machine during all driving and swing operations.
- Under all travel conditions, the operator must limit travel speed according to conditions of ground surface, congestion, visibility, slope, location of personnel, and other factors which may cause collision or injury to personnel.
- Be aware of stopping distances in all drive speeds. When driving in high speed, switch to low speed before stopping. Travel grades in low speed only.
- Do not use high speed drive in restricted or close quarters or when driving in reverse.
- Exercise extreme caution at all times to prevent obstacles from striking or interfering with operating controls and persons in the platform.
- Be sure that operators of other overhead and floor level machines are aware of the aerial work platform's presence. Disconnect power to overhead cranes.
- Warn personnel not to work, stand, or walk under a raised boom or platform. Position barricades on floor if necessary.



## **1.4 TOWING, LIFTING, AND HAULING**

- Never allow personnel in platform while towing, lifting, or hauling.
- This machine should not be towed, except in the event of emergency, malfunction, power failure, or loading/unloading. Refer to the Emergency Procedures section of this manual for emergency towing procedures.
- Ensure boom is in the stowed position and the turntable locked prior to towing, lifting or hauling. The platform must be completely empty of tools.
- When lifting machine, lift only at designated areas of the machine. Lift the unit with equipment of adequate capacity.
- Refer to the Machine Operation section of this manual for lifting information.

## **1.5 MAINTENANCE**

This sub-section contains general safety precautions which must be observed during maintenance of this machine. Additional precautions to be observed during machine maintenance are inserted at the appropriate points in this manual and in the Service and Maintenance Manual. It is of utmost importance that maintenance personnel pay strict attention to these precautions to avoid possible injury to personnel or damage to the machine or property. A maintenance program must be established by a qualified person and must be followed to ensure that the machine is safe.

### **Maintenance Hazards**

- Shut off power to all controls and ensure that all moving parts are secured from inadvertent motion prior to performing any adjustments or repairs.
- Never work under an elevated platform until it has been fully lowered to the full down position, if possible, or otherwise supported and restrained from movement with appropriate safety props, blocking, or overhead supports.
- DO NOT attempt to repair or tighten any hydraulic hoses or fittings while the machine is powered on or when the hydraulic system is under pressure.
- Always relieve hydraulic pressure from all hydraulic circuits before loosening or removing hydraulic components.

## SECTION 1 - SAFETY PRECAUTIONS

---

- DO NOT use your hand to check for leaks. Use a piece of cardboard or paper to search for leaks. Wear gloves to help protect hands from spraying fluid.



- Ensure replacement parts or components are identical or equivalent to original parts or components.
- Never attempt to move heavy parts without the aid of a mechanical device. Do not allow heavy objects to rest in an unstable position. Ensure adequate support is provided when raising components of the machine.

- Do not use machine as a ground for welding.
- When performing welding or metal cutting operations, precautions must be taken to protect the chassis from direct exposure to weld and metal cutting spatter.
- Do not refuel the machine with the engine running.
- Use only approved non-flammable cleaning solvents.
- Do not replace items critical to stability, such as batteries or solid tires, with items of different weight or specification. Do not modify unit in any way to affect stability.
- Refer to the Service and Maintenance Manual for the weights of critical stability items.

### **⚠ WARNING**

**MODIFICATION OR ALTERATION OF AN AERIAL WORK PLATFORM SHALL BE MADE ONLY WITH PRIOR WRITTEN PERMISSION FROM THE MANUFACTURER.**

## **Battery Hazards**

- Always disconnect batteries when servicing electrical components or when performing welding on the machine.
- Do not allow smoking, open flame, or sparks near battery during charging or servicing.
- Do not contact tools or other metal objects across the battery terminals.
- Always wear hand, eye, and face protection when servicing batteries. Ensure that battery acid does not come in contact with skin or clothing.

### **CAUTION**

**BATTERY FLUID IS HIGHLY CORROSIVE. AVOID CONTACT WITH SKIN AND CLOTHING AT ALL TIMES. IMMEDIATELY RINSE ANY CONTACTED AREA WITH CLEAN WATER AND SEEK MEDICAL ATTENTION.**

- Charge batteries only in a well ventilated area.
- Avoid overfilling the battery fluid level. Add distilled water to batteries only after the batteries are fully charged.

**SECTION 1 - SAFETY PRECAUTIONS**

---



**NOTES:**

<hr/>	<hr/>
<hr/>	<hr/>
<hr/>	<hr/>
<hr/>	<hr/>
<hr/>	<hr/>
<hr/>	<hr/>
<hr/>	<hr/>
<hr/>	<hr/>
<hr/>	<hr/>
<hr/>	<hr/>
<hr/>	<hr/>
<hr/>	<hr/>
<hr/>	<hr/>
<hr/>	<hr/>
<hr/>	<hr/>
<hr/>	<hr/>
<hr/>	<hr/>
<hr/>	<hr/>
<hr/>	<hr/>
<hr/>	<hr/>
<hr/>	<hr/>
<hr/>	<hr/>

## **SECTION 2. USER RESPONSIBILITIES, MACHINE PREPARATION, AND INSPECTION**

### **2.1 PERSONNEL TRAINING**

The aerial platform is a personnel handling device; so it is necessary that it be operated and maintained only by trained personnel.

Persons under the influence of drugs or alcohol or who are subject to seizures, dizziness or loss of physical control must not operate this machine.

#### **Operator Training**

Operator training must cover:

1. Use and limitations of the controls in the platform and at the ground, emergency controls and safety systems.
2. Control labels, instructions, and warnings on the machine.
3. Rules of the employer and government regulations.
4. Use of approved fall protection device.
5. Enough knowledge of the mechanical operation of the machine to recognize a malfunction or potential malfunction.

6. The safest means to operate the machine where overhead obstructions, other moving equipment, and obstacles, depressions, holes, dropoffs.
7. Means to avoid the hazards of unprotected electrical conductors.
8. Specific job requirements or machine application.

#### **Training Supervision**

Training must be done under the supervision of a qualified person in an open area free of obstructions until the trainee has developed the ability to safely control and operate the machine.

#### **Operator Responsibility**

The operator must be instructed that he/she has the responsibility and authority to shut down the machine in case of a malfunction or other unsafe condition of either the machine or the job site.

## **2.2 PREPARATION, INSPECTION, AND MAINTENANCE**

The following table covers the periodic machine inspections and maintenance recommended by JLG Industries, Inc. Consult local regulations for further requirements for aerial work platforms. The frequency of inspections and maintenance must be increased as necessary when the machine is used in a harsh or hostile environment, if the machine is used with increased frequency, or if the machine is used in a severe manner.

### **NOTICE**

**JLG INDUSTRIES, INC. RECOGNIZES A FACTORY TRAINED SERVICE TECHNICIAN AS A PERSON WHO HAS SUCCESSFULLY COMPLETED THE JLG SERVICE TRAINING SCHOOL FOR THE SPECIFIC JLG PRODUCT MODEL.**

## SECTION 2 - USER RESPONSIBILITIES, MACHINE PREPARATION, AND INSPECTION

**Table 2-1. Inspection and Maintenance Table**

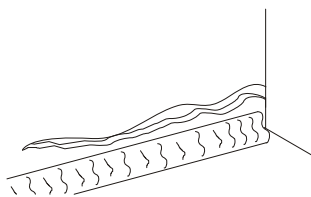
Type	Frequency	Primary Responsibility	Service Qualification	Reference
Pre-Start Inspection	Before using each day; or whenever there's an Operator change.	User or Operator	User or Operator	Operator and Safety Manual
Pre-Delivery Inspection (See Note)	Before each sale, lease, or rental delivery.	Owner, Dealer, or User	Qualified JLG Mechanic	Service and Maintenance Manual and applicable JLG inspection form
Frequent Inspection	In service for 3 months or 150 hours, whichever comes first; or Out of service for a period of more than 3 months; or Purchased used.	Owner, Dealer, or User	Qualified JLG Mechanic	Service and Maintenance Manual and applicable JLG inspection form
Annual Machine Inspection	Annually, no later than 13 months from the date of prior inspection.	Owner, Dealer, or User	Factory Trained Service Technician (Recommended)	Service and Maintenance Manual and applicable JLG inspection form
Preventative Maintenance	At intervals as specified in the Service and Maintenance Manual.	Owner, Dealer, or User	Qualified JLG Mechanic	Service and Maintenance Manual
<b>NOTE:</b> Inspection forms are available from JLG. Use the Service and Maintenance Manual to perform inspections.				

## SECTION 2 - USER RESPONSIBILITIES, MACHINE PREPARATION, AND INSPECTION

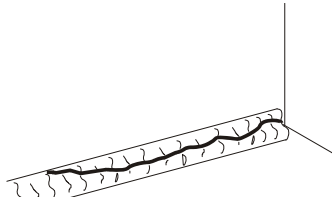
### Pre-Start Inspection

The Pre-Start Inspection should include each of the following:

1. **Cleanliness** – Check all surfaces for leakage (oil, fuel, or battery fluid) or foreign objects. Report any leakage to the proper maintenance personnel.
2. **Structure** - Inspect the machine structure for dents, damage, weld or parent metal cracks or other discrepancies.



Parent Metal Crack



Weld Crack

3. **Decals and Placards** – Check all for cleanliness and legibility. Make sure none of the decals and placards are missing. Make sure all illegible decals and placards are cleaned or replaced.
4. **Operators and Safety Manuals** – Make sure a copy of the Operator and Safety Manual, AEM Safety Manual (Domestic only), and ANSI Manual of Responsibilities (Domestic only) is enclosed in the weather resistant storage container.

5. **“Walk-Around” Inspection** – Refer to Figure 2-3. thru Figure 2-7.
6. **Battery** – Charge as required.
7. **Fuel** (Combustion Engine Powered Machines) – Add the proper fuel as necessary.
8. **Engine Oil Supply** - Ensure the engine oil level is at the Full mark on the dipstick and the filler cap is secure.
9. **Hydraulic Oil** – Check the hydraulic oil level. Ensure hydraulic oil is added as required.
10. **Accessories/Attachments** - Reference the Operation and Safety Manual of each attachment or accessory installed upon the machine for specific inspection, operation, and maintenance instructions.
11. **Function Check** – Once the “Walk-Around” Inspection is complete, perform a functional check of all systems in an area free of overhead and ground level obstructions. Refer to Section 4 for more specific instructions.

### **WARNING**

**IF THE MACHINE DOES NOT OPERATE PROPERLY, TURN OFF THE MACHINE IMMEDIATELY! REPORT THE PROBLEM TO THE PROPER MAINTENANCE PERSONNEL. DO NOT OPERATE THE MACHINE UNTIL IT IS DECLARED SAFE FOR OPERATION.**



### Function Check

Perform the Function Check as follows:

1. From the ground control panel with no load in the platform:
  - a. Check that all guards protecting the switches or locks are in place;
  - b. Operate all functions and check all limiting and cut-out switches;
  - c. Check auxiliary power (or manual descent);
  - d. Ensure that all machine functions are disabled when the Emergency Stop Button is activated.
2. From the platform control console:
  - a. Ensure that the control console is firmly secured in the proper location;
  - b. Check that all guards protecting the switches or locks are in place;
  - c. Operate all functions and check all limiting and cut-out switches;
  - d. Ensure that all machine functions are disabled when the Emergency Stop Button is pushed in.
3. With the platform in the transport (stowed) position:
  - a. Drive the machine on a grade, not to exceed the rated gradeability, and stop to ensure the brakes hold;
  - b. Check the tilt sensor alarm to ensure proper operation.

### 2.3 LIMIT SWITCH FUNCTIONAL CHECK

#### **WARNING**

**TO AVOID COLLISION AND INJURY IF PLATFORM DOES NOT STOP WHEN A CONTROL SWITCH OR LEVER IS RELEASED, REMOVE FOOT FROM FOOTSWITCH OR USE EMERGENCY STOP TO STOP THE MACHINE.**

**NOTE:** Perform checks from ground controls first, then from platform controls.

1. Operate machine from ground control.

**NOTE:** For adjustments see Service Manual - Limit Switch Adjustments.

2. Check elevation limit switch as follows:
  - a. Lift boom up to 2 degrees to 7 degrees above horizontal. The switch should activate at this point.
  - b. Lift boom down to 2.5 degrees to 7.5 degrees below horizontal. The switch should reset at this point.
3. Raise main boom, extend and retract telescope. Check for delayed movement of fly section, indicating loose cables.

4. Swing turntable to LEFT and RIGHT a minimum of 45 degrees. Check for smooth motion.
5. Check the chassis out of level indicator located on the platform control console by driving, with the machine in level position, up a suitable ramp of at least 5° slope. Check the out of level indicator, with the machine on the ramp. If the light does not illuminate, return the machine to a level surface, shut down the machine, and contact a qualified technician before resuming operation.

**NOTE:** Steps 6 & 7 cover 600S ANSI market machines with dual capacities (500 & 1000 lb. [227 kg for ANSI markets and 230 kg for CE and Australia markets & 454 kg for ANSI markets and 450 kg for CE and Australia markets]).

6. Check capacity limit switch as follows:

Boom Length Switch.

- a. Raise boom to horizontal (place angle indicator on base boom between boom pivot pin and lift cylinder attach pin).
- b. Telescope boom out until 500 lb. (227 kg for ANSI markets and 230 kg for CE and Australia markets) light comes on (may need to use auxiliary power to position boom correctly).

## SECTION 2 - USER RESPONSIBILITIES, MACHINE PREPARATION, AND INSPECTION

- c. Mark wear pad location on the fly and mid booms.
- d. Telescope boom out to full extension.
- e. Measure from the mark on the fly boom to the wear pad and measure from mark on the mid boom to the wear pad.
- f. Add These two numbers together (they should be approximately equal) they should measure 137" to 139" (348 to 353 cm).

### Boom Angle Switch.

- a. Telescope boom to full extension.
- b. Lift boom up until 1000 lb. (454 kg for ANSI markets and 450 kg for CE and Australia markets) light comes on.
- c. Lift boom down using auxiliary power until 500 lb. (227 kg for ANSI markets and 230 kg for CE and Australia markets) light comes on. Boom angle must be 45 degrees to 50 degrees (place angle indicator on base boom between boom pivot pin and lift cylinder attach pin).

- d. Lift boom up until 1000 lb. (454 kg for ANSI markets and 450 kg for CE and Australia markets) light comes on. Boom angle should be 55 degrees to 64 degrees.

**NOTE:** *If limit switch settings need to be changed, you will need to recheck that the 500 lb. (227 kg for ANSI markets and 230 kg for CE and Australia markets) light comes on at 45 degrees to 50 degrees when lifting down.*

### 7. Check capacity limit switch as follows:

#### Main Boom Length Switch.

- a. Lift main boom to approximately horizontal.
- b. Telescope boom out until 500 lb. (227 kg for ANSI markets and 230 kg for CE and Australia markets) light comes on (may need to used auxiliary power to position boom correctly).
- c. Mark the wear pad location on the main fly boom.
- d. Telescope the main boom to full extension.
- e. Measure from the mark on the fly boom to the wear pad. The dimension should be 125" to 127" (317.5 to 322.5 cm).

## SECTION 2 - USER RESPONSIBILITIES, MACHINE PREPARATION, AND INSPECTION

---

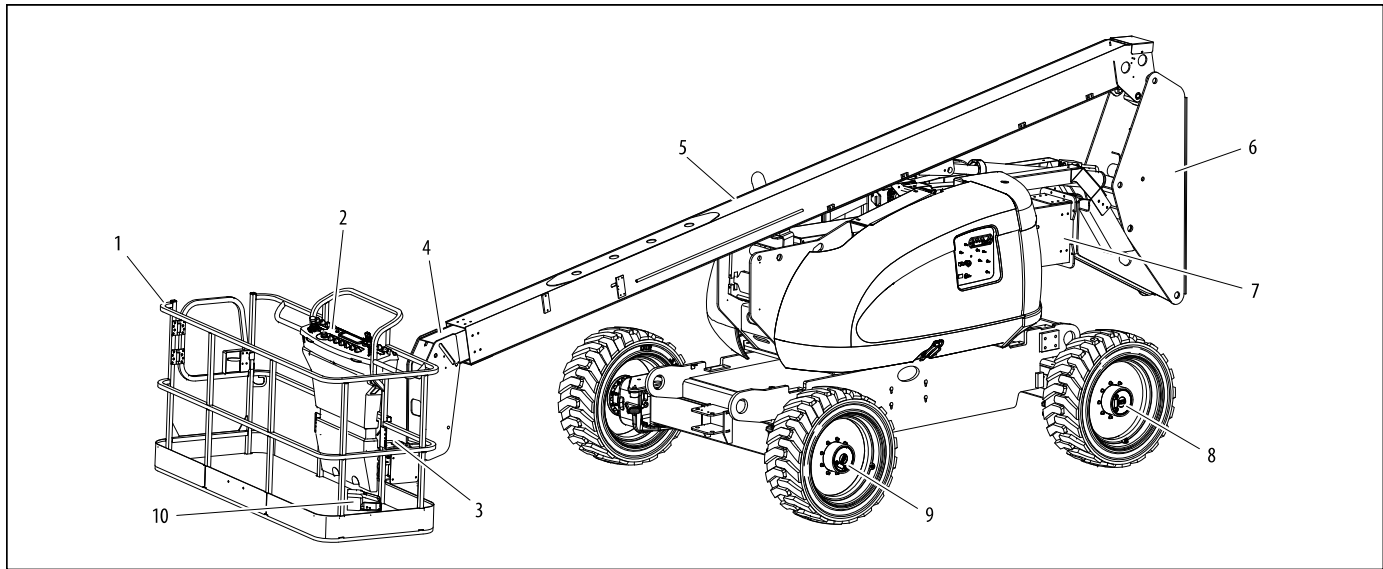
Main Boom Angle Switch.

- a. Lift main boom to approximately horizontal.
- b. Telescope boom out until 500 lb. (227 kg for ANSI markets and 230 kg for CE and Australia markets) light comes on (may need to use auxiliary power to position boom correctly).
- c. Lift main boom up until 1000 lb. (454 kg for ANSI markets and 450 kg for CE and Australia markets) light comes on. The boom angle at this point should be 55 degrees to 60 degrees.

- d. Lift main boom down until 500 lb. (227 kg for ANSI markets and 230 kg for CE and Australia markets) light comes on. The boom angle at this point should be 45 degrees to 50 degrees.

**NOTE:** *If limit switch settings need to be changed, you will need to recheck that the 500 lb. (227 kg for ANSI markets and 230 kg for CE and Australia markets) light comes on at 45 degrees to 50 degrees when lifting down.*

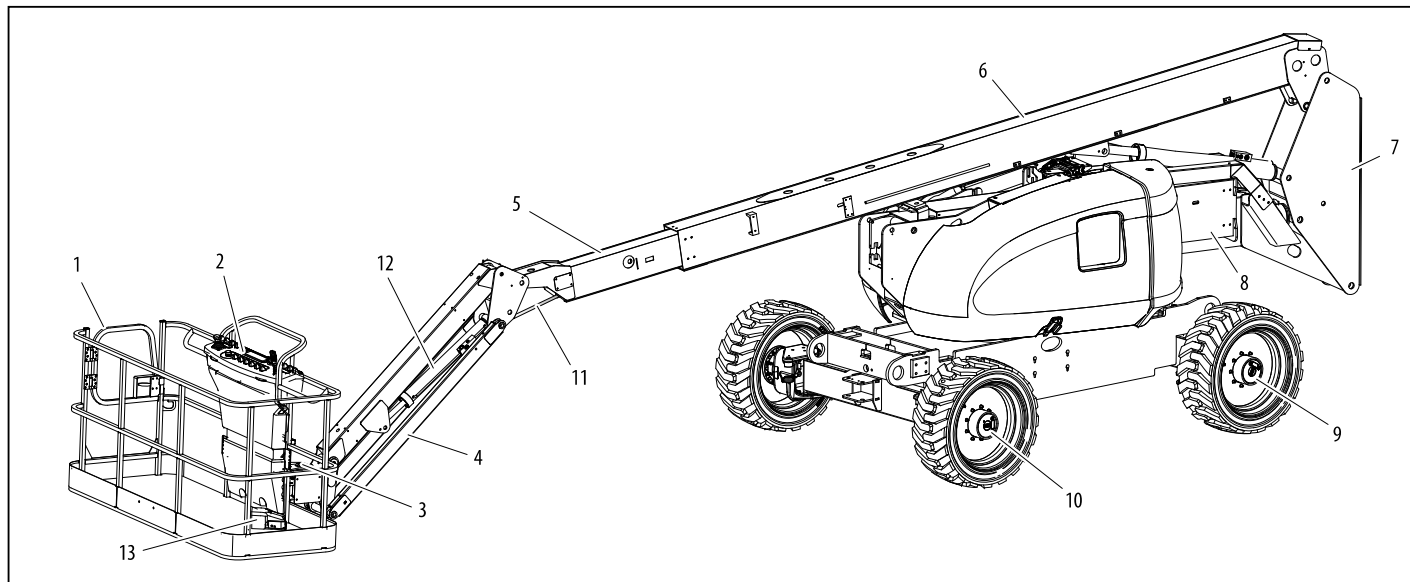
## SECTION 2 - USER RESPONSIBILITIES, MACHINE PREPARATION, AND INSPECTION



- |                         |               |                             |
|-------------------------|---------------|-----------------------------|
| 1. Platform             | 5. Base Boom  | 8. Front Drive/Steer Wheels |
| 2. Platform Control Box | 6. Upright    | 9. Rear Drive Wheels        |
| 3. Rotator              | 7. Tower Boom | 10. Footswitch              |
| 4. Fly Boom             |               |                             |

**Figure 2-1. Basic Nomenclature - 600A**

## SECTION 2 - USER RESPONSIBILITIES, MACHINE PREPARATION, AND INSPECTION



**Figure 2-2. Basic Nomenclature - 600AJ**

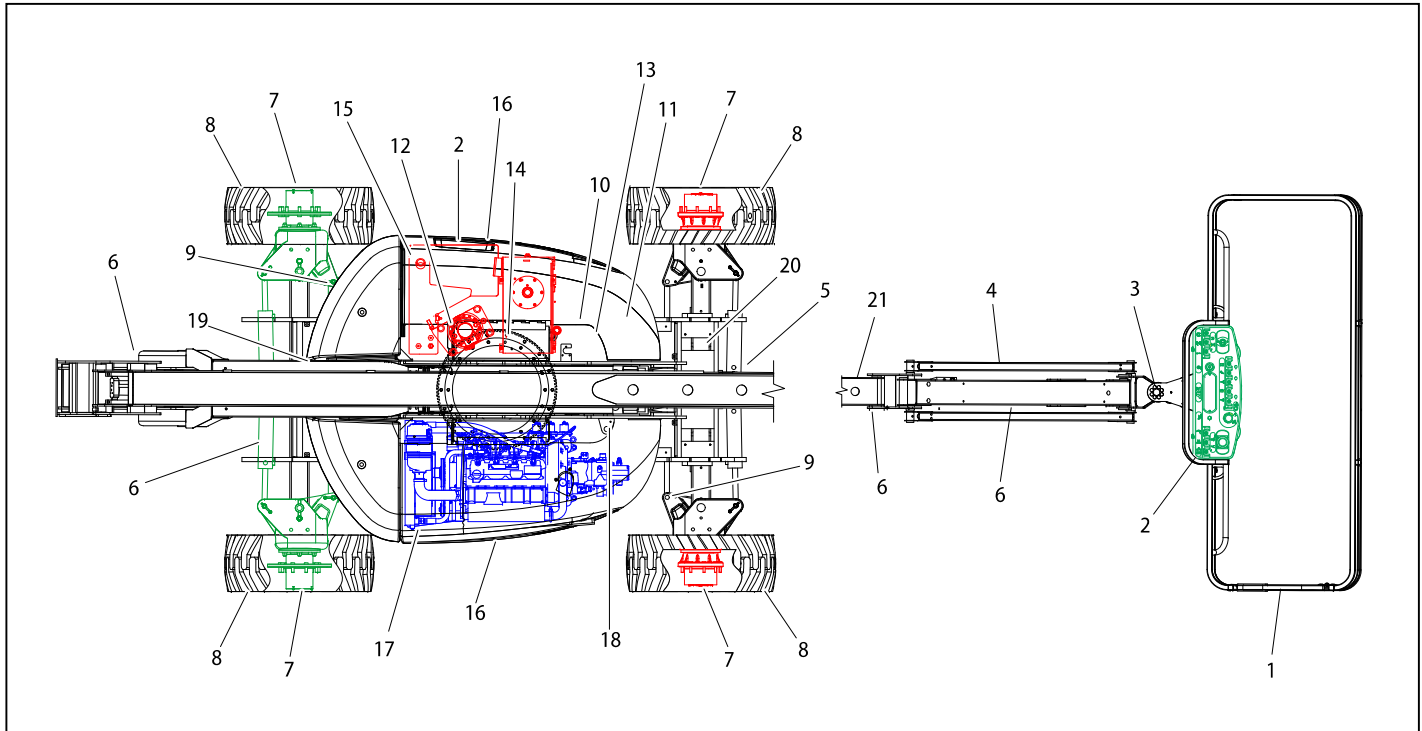


Figure 2-3. Daily Walk-Around Inspection Diagram - Deutz D2011L04

## SECTION 2 - USER RESPONSIBILITIES, MACHINE PREPARATION, AND INSPECTION

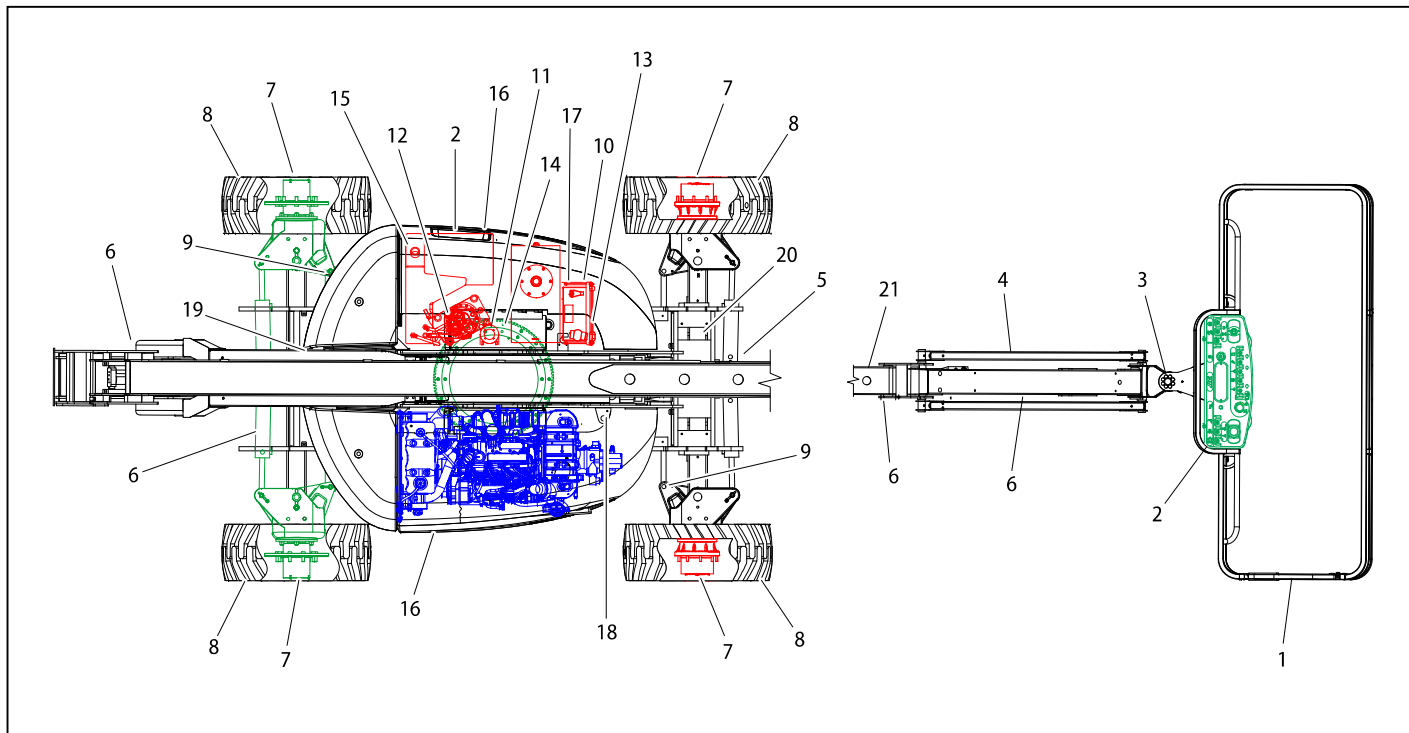


Figure 2-4. Daily Walk-Around Inspection Diagram - Deutz TD2.9



## SECTION 2 - USER RESPONSIBILITIES, MACHINE PREPARATION, AND INSPECTION

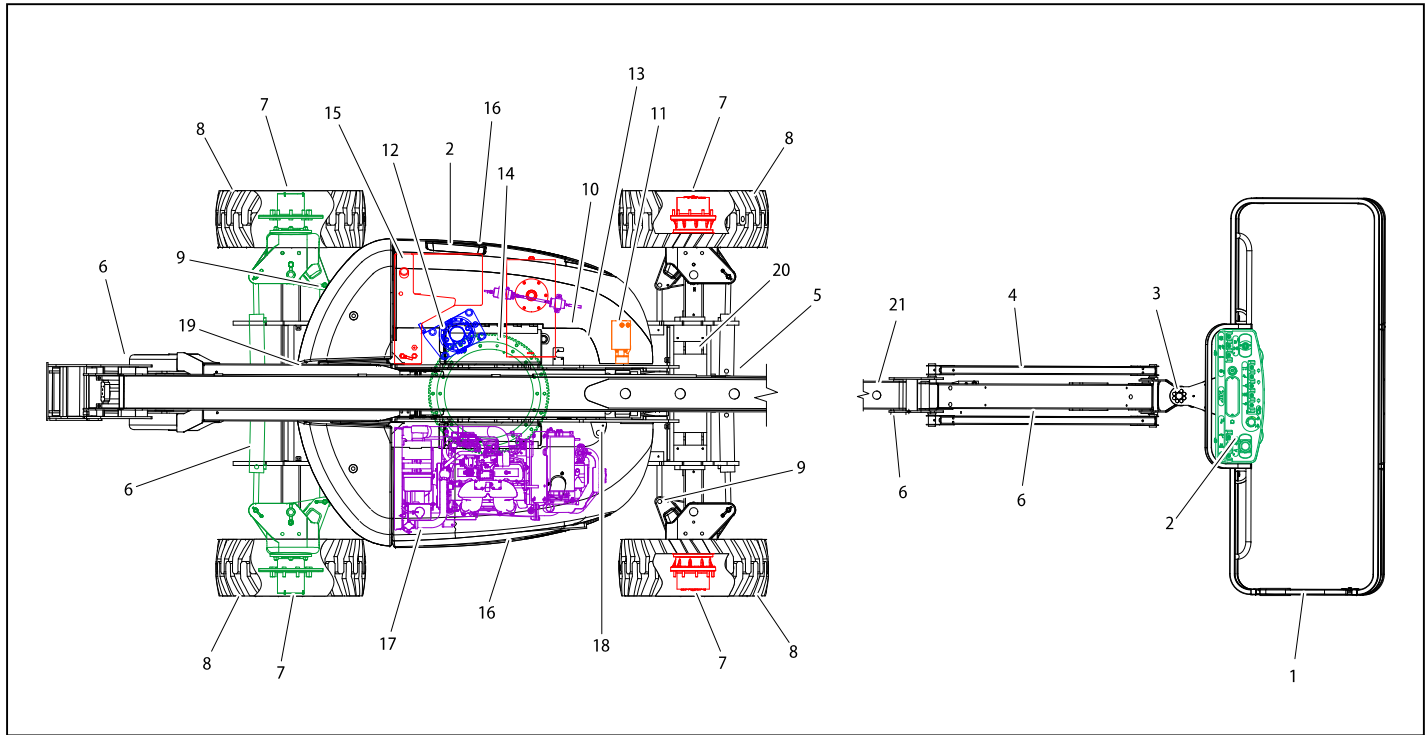


Figure 2-5. Daily Walk-Around Inspection Diagram - GM 3.0L

### General

Begin the "Walk-Around Inspection" at Item 1, as noted on the diagram. Continue checking each item in sequence for the conditions listed in the following checklist.

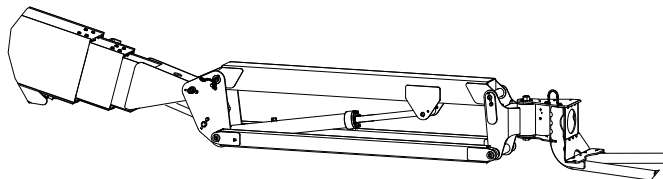
#### **⚠ WARNING**

**TO AVOID POSSIBLE INJURY BE SURE MACHINE POWER IS OFF.**

**INSPECTION NOTE:** *On all components, make sure there are no loose or missing parts, that they are securely fastened, and no visible damage, leaks or excessive wear exists in addition to any other criteria mentioned.*

1. Platform Assembly and Gate - Footswitch works properly, not modified, disabled or blocked. Latch and hinges in working condition.
2. Platform & Ground Control Consoles - Switches and levers return to neutral, decals/placards secure and legible, control markings legible.
3. Rotator - See Inspection Note.

4. Jib (If Equipped) - See Inspection Note.



5. Power Track - See Inspection Note.
6. All Hydraulic Cylinders - See Inspection Note.
7. Drive Motor, Brake, and Hub - See Inspection Note.
8. Wheel/Tire Assemblies - Properly secured, no missing lug nuts. Inspect for worn tread, cuts, tears or other discrepancies. Inspect wheels for damage and corrosion.
9. Tie Rod and Steering Linkage - See Inspection Note.
10. Turntable Lock - Operable.

**Figure 2-6. Daily Walk-Around Inspection Points - Sheet 1 of 2**

## **SECTION 2 - USER RESPONSIBILITIES, MACHINE PREPARATION, AND INSPECTION**

---

11. Auxiliary Power Pump - See Inspection Note.
12. Swing Drive Motor and Brake - See Inspection Note.
13. Main Control Valve - See Inspection Note.
14. Turntable Bearing - Evidence of proper lubrication. No evidence of loose bolts or looseness between bearing and structure.
15. Fuel Tank - See Inspection Note.
16. Hood Assemblies - See Inspection Note.
17. Battery - Proper electrolyte levels if adjustable; cables tight, no visible damage or corrosion.
18. Hydraulic Pump - See Inspection Note.
19. Turntable - See Inspection Note.
20. Frame - See Inspection Note.
21. Main Boom Sections - See Inspection Note.

**Figure 2-7. Daily Walk-Around Inspection Points - Sheet 2 of 2**

**SECTION 2 - USER RESPONSIBILITIES, MACHINE PREPARATION, AND INSPECTION**

---

 **NOTES:**

<hr/>	<hr/>
<hr/>	<hr/>
<hr/>	<hr/>
<hr/>	<hr/>
<hr/>	<hr/>
<hr/>	<hr/>
<hr/>	<hr/>
<hr/>	<hr/>
<hr/>	<hr/>
<hr/>	<hr/>
<hr/>	<hr/>
<hr/>	<hr/>
<hr/>	<hr/>
<hr/>	<hr/>
<hr/>	<hr/>
<hr/>	<hr/>
<hr/>	<hr/>
<hr/>	<hr/>
<hr/>	<hr/>
<hr/>	<hr/>
<hr/>	<hr/>

## SECTION 3. MACHINE CONTROLS AND INDICATORS

### 3.1 GENERAL

#### **NOTICE**

**THE MANUFACTURER HAS NO DIRECT CONTROL OVER MACHINE APPLICATION AND OPERATION. THE USER AND OPERATOR ARE RESPONSIBLE FOR CONFORMING WITH GOOD SAFETY PRACTICES.**

This section provides the necessary information needed to understand control functions.

### 3.2 CONTROLS AND INDICATORS

**NOTE:** All machines are equipped with control panels that use symbols to indicate control functions. On ANSI machines refer to decal located on the control box guard in front of the control box or by the ground controls for these symbols and the corresponding functions.

**NOTE:** The indicator panels use different shaped symbols to alert the operator to different types of operational situations that could arise. The meaning of those symbols are explained below.



Indicates a potentially hazardous situation, which if not corrected, could result in serious injury or death. This indicator will be red.



Indicates an abnormal operating condition, which if not corrected, may result in machine interruption or damage. This indicator will be yellow.



Indicates important information regarding the operating condition, i.e. procedures essential for safe operation. This indicator will be green with the exception of the capacity indicator which will be green or yellow depending upon platform position.

### Ground Control Station

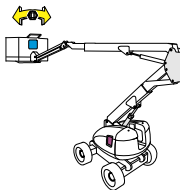
(See Figure 3-2. and Figure 3-1.)

**NOTE:** If equipped, the Function Enable switch must be held down in order to operate Main Boom Telescope, Tower Lift, Swing, Main Lift, Jib Lift, Platform Level Override, and Platform Rotate functions.



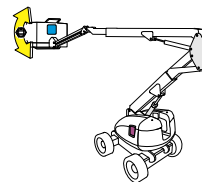
#### 1. Platform Rotate

Provides rotation of the platform.



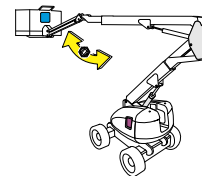
#### 2. Platform Leveling Override

A three position switch allows the operator to adjust the automatic self leveling system. This switch is used to adjust platform level in situations such as ascending/descending a grade.



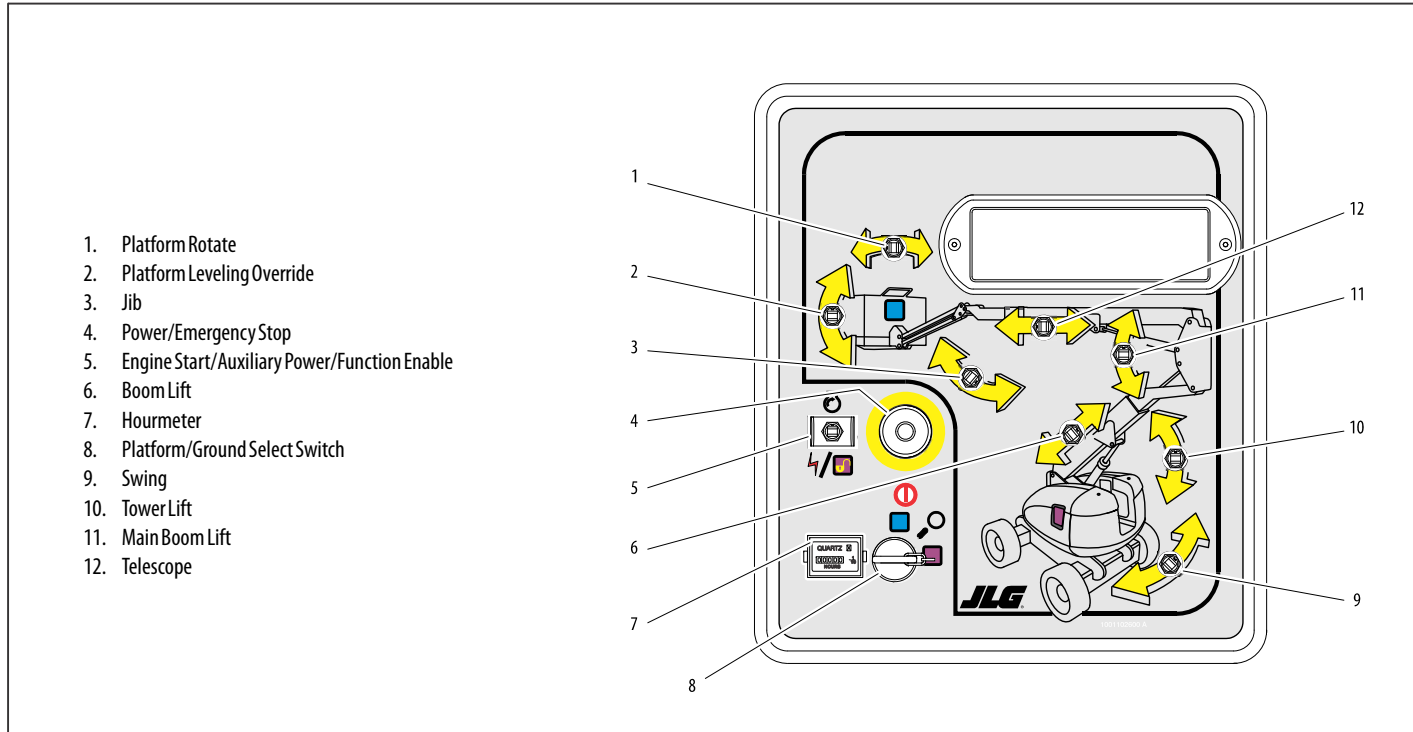
#### 3. Jib (If Equipped)

This switch provides raising and lowering of the jib.



### **⚠ WARNING**

**ONLY USE THE PLATFORM LEVELING OVERRIDE FUNCTION FOR SLIGHT LEVELING OF THE PLATFORM. INCORRECT USE COULD CAUSE THE LOAD/OCCUPANT TO SHIFT OR FALL. FAILURE TO DO SO COULD RESULT IN DEATH OR SERIOUS INJURY.**



**Figure 3-1. Ground Control Station - 600AJ**

## SECTION 3 - MACHINE CONTROLS AND INDICATORS

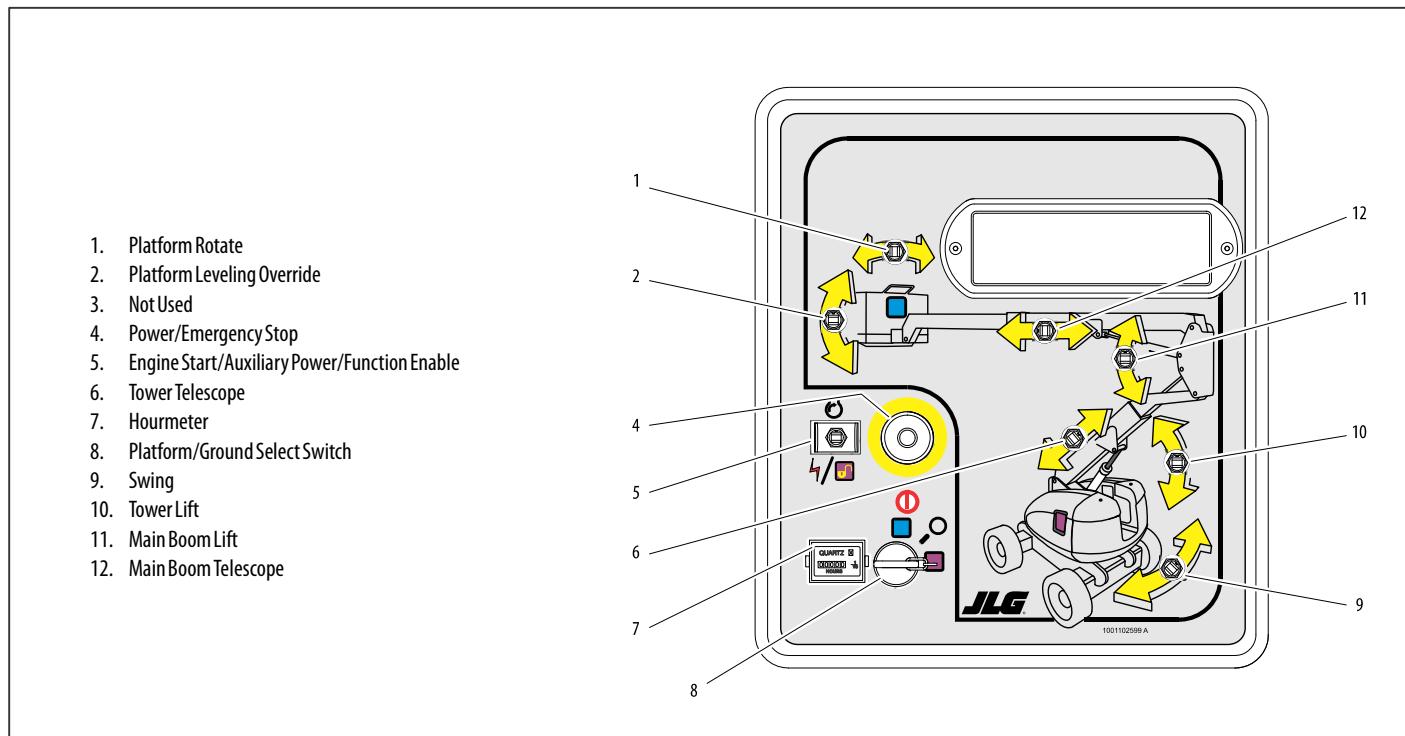


Figure 3-2. Ground Control Station - 600A



## SECTION 3 - MACHINE CONTROLS AND INDICATORS

**NOTE:** When Power/Emergency Stop switch is in the "On" position and engine is not running, an alarm will sound, indicating Ignition is "On".

### CAUTION

**WHEN THE MACHINE IS SHUT DOWN THE MASTER/EMERGENCY STOP SWITCH MUST BE POSITIONED TO THE "OFF" POSITION TO PREVENT DRAINING THE BATTERY.**

**NOTE:** On machines with diesel engines, when Glow Plug Indicator is lighted (Yellow), wait until light goes out before cranking engine.

#### 4. Power/Emergency Stop Switch

A two-position red mushroom shaped switch supplies power to Platform/Ground Select switch when pulled out (on). When pushed in (off), power is shut off to the Platform/Ground Select switch.



#### 5. Engine Start/ Auxiliary Power Switch /Function Enable



To start the engine, the switch must be held "Up" until the engine starts.

To use auxiliary power, the switch must be held "Down" for duration of auxiliary pump use.



When the engine is running, the switch must be held "Down" to enable all boom controls.



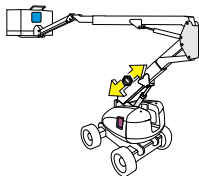
### CAUTION

**WHEN OPERATING ON AUXILIARY POWER, DO NOT OPERATE MORE THAN ONE FUNCTION AT A TIME. (SIMULTANEOUS OPERATION CAN OVERLOAD THE AUXILIARY PUMP MOTOR.)**

## SECTION 3 - MACHINE CONTROLS AND INDICATORS

### 6. Tower Telescope

This switch provides extending and retracting of the tower boom. This function works only when the tower boom is fully elevated (lift up).

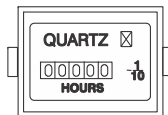


### **⚠ WARNING**

**TO AVOID UPSET AND SERIOUS INJURY, DO NOT OPERATE MACHINE IF TOWER LIFT AND TELESCOPE FUNCTIONS DO NOT OPERATE IN THE ABOVE SEQUENCE.**

### 7. Hourmeter

Registers the amount of time the machine has been in use, with engine running. By connecting into the oil pressure circuit of the engine, only engine run hours are recorded. The hourmeter registers up to 9,999.9 hours and cannot be reset.

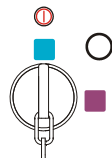


**NOTE:** When the Platform/Ground Select Switch is in the center position, power is shut off to the controls at both operating stations. Remove the key to prevent the controls from being actuated. The key is removable in the platform position on CE specification machines. The key must be available to ground personnel in the event of an emergency.



### 8. Platform/Ground Select Switch

The three position, key operated switch supplies power to the platform control console when positioned to Platform. With the switch key turned to the Ground position only ground controls are operable.



## SECTION 3 - MACHINE CONTROLS AND INDICATORS

**NOTE:** Main Lift, Tower Lift, Swing, Platform Level, Main Telescope, Tower Telescope, Platform Rotator and Auxiliary Power control switches are spring-loaded and will automatically return to neutral (off) when released.

### **⚠ WARNING**

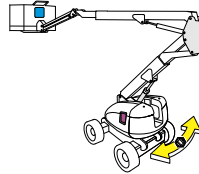
**WHEN OPERATING THE BOOM ENSURE THERE ARE NO PERSONNEL AROUND OR UNDER PLATFORM.**

### **⚠ WARNING**

**TO AVOID SERIOUS INJURY, DO NOT OPERATE MACHINE IF ANY CONTROL LEVERS OR TOGGLE SWITCHES CONTROLLING PLATFORM MOVEMENT DO NOT RETURN TO THE OFF POSITION WHEN RELEASED.**

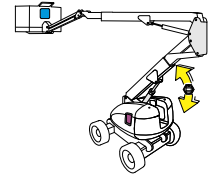
#### 9. Swing Control

Provides 360 degrees continuous turntable rotation.



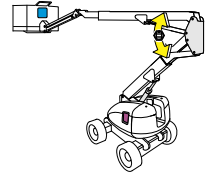
#### 10. Tower Lift

This switch provides raising and lowering of the tower boom. This function works only when the tower boom is fully retracted.



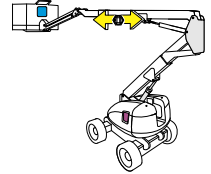
#### 11. Main Boom Lift Control

Provides raising and lowering of the main boom.



#### 12. Main Telescope Control

Provides extension and retraction of the main boom.



### Ground Control Indicator Panel

(See Figure 3-3.)

1. No Alternator Output Indicator

Indicates a problem in the charging circuit, and service is required.



2. Engine Oil Pressure Indicator

Indicates that engine oil pressure is below normal and service is required.



3. High Engine Coolant Temperature Indicator (Liquid Cooled Engines)

Indicates that engine coolant temperature is abnormally high and service is required.



4. Engine Oil Temperature Indicator (Deutz)

Indicates that the temperature of the engine oil, which also serves as engine coolant, is abnormally high and service is required.

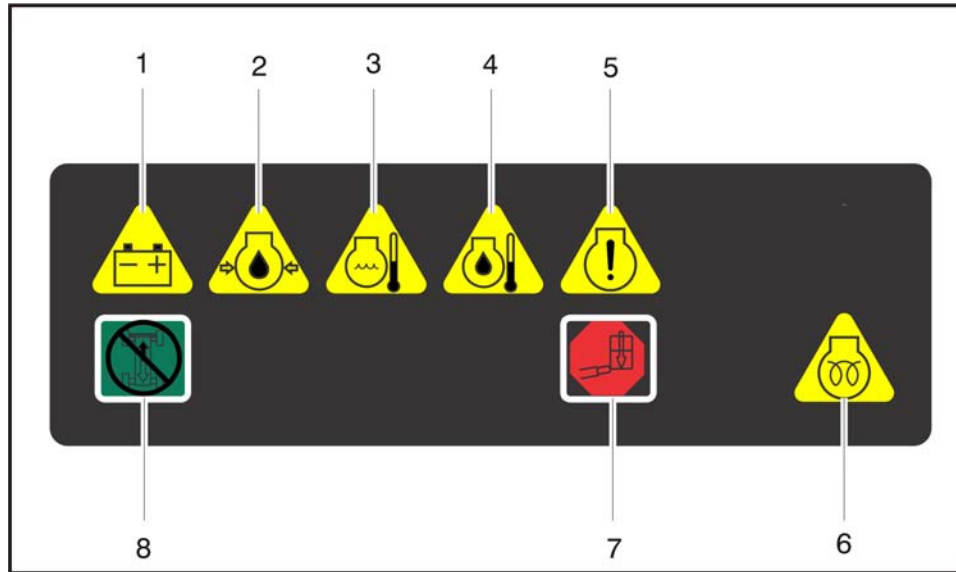


5. System Distress Indicator

The light indicates that the JLG Control System has detected an abnormal condition and a Diagnostic Trouble Code has been set in the system memory. Refer to the Service Manual for instructions concerning the trouble codes and trouble code retrieval.



The system distress indicator light will illuminate for 2-3 seconds when the key is positioned to the on position to act as a self test.



- |                              |                            |
|------------------------------|----------------------------|
| 1. No Alternator Output      | 5. System Distress         |
| 2. Low Engine Oil Pressure   | 6. Glow Plug Wait to Start |
| 3. High Engine Coolant Temp. | 7. Platform Overload       |
| 4. Engine Oil Temp.          | 8. Drive and Steer Disable |

**Figure 3-3. Ground Control Indicator Panel**

## SECTION 3 - MACHINE CONTROLS AND INDICATORS

### 6. Glow Plug/ Wait to Start Indicator

Indicates the glow plugs are on. The glow plugs are automatically turned on with the ignition circuit and remain on for approximately seven seconds. Start the engine only after the light goes out.



### 7. Platform Overload Indicator. (If Equipped)

Indicates the platform has been overloaded.



### 8. Drive and Steer Disable Indicator (If equipped)

Indicates the Drive and Steer Disable function has been activated.



## Platform Station

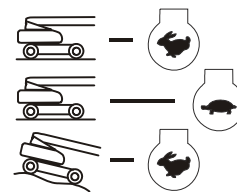
(See Figure 3-4.)

### **! WARNING**

**TO AVOID SERIOUS INJURY, DO NOT OPERATE MACHINE IF ANY CONTROL LEVERS OR TOGGLE SWITCHES CONTROLLING PLATFORM MOVEMENT DO NOT RETURN TO THE OFF OR NEUTRAL POSITION WHEN RELEASED.**

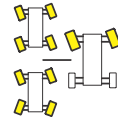
#### 1. Drive Speed/Torque Select

The machine has a two position switch - The forward position gives maximum drive speed. The back position gives maximum torque for rough terrain and climbing grades.



### 2. Steer Select (If Equipped)

When equipped with four wheel steering, the action of the steering system is operator selectable. The center switch position gives conventional front wheel steering with the rear wheels unaffected. This is for normal driving at maximum speeds. The forward position is for “crab” steering. When in this mode both front and rear axles steer in the same direction, which allows the chassis to move sideways as it goes forward. This can be used for positioning the machine in aisle ways or against buildings. The back switch position is for “coordinated” steering. In this mode the front and rear axles steer in the opposite directions to produce the tightest turning circle for maneuvering in confined areas.



To re-synchronize the front and rear axles, position the rear drive wheels to the forward drive position by selecting either crab or compound steer, then select front steer (center switch position) to operate the normal steering function.

### **⚠ WARNING**

**ONLY USE THE PLATFORM LEVELING OVERRIDE FUNCTION FOR SLIGHT LEVELING OF THE PLATFORM. INCORRECT USE COULD CAUSE THE LOAD/OCCUPANTS TO SHIFT OR FALL. FAILURE TO DO SO COULD RESULT IN DEATH OR SERIOUS INJURY.**

### 3. Platform Leveling Override

A three position switch allows the operator to adjust the automatic self leveling system. This switch is used to adjust platform level in situations such as ascending/descending a grade.

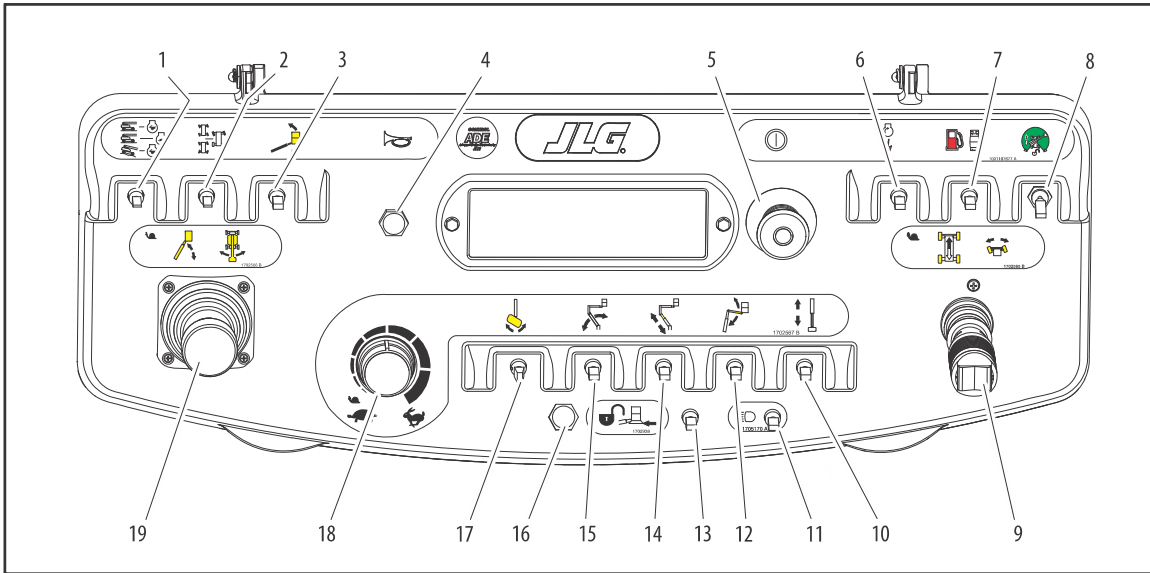


### 4. Horn

A push-type Horn switch supplies electrical power to an audible warning device when pressed.



## SECTION 3 - MACHINE CONTROLS AND INDICATORS



- |                               |                               |                         |                          |
|-------------------------------|-------------------------------|-------------------------|--------------------------|
| 1. Drive Speed                | 6. Start/Aux. Power           | 11. Lights              | 16. Soft Touch Indicator |
| 2. Steer Select               | 7. Fuel Select                | 12. Jib                 | 17. Platform Rotate      |
| 3. Platform Leveling Override | 8. Drive Orientation Override | 13. Soft Touch Override | 18. Function Speed       |
| 4. Horn                       | 9. Drive/Steer                | 14. Tower Telescope     | 19. Main Lift/Swing      |
| 5. Power/Emergency Stop       | 10. Main Boom Telescope       | 15. Tower Lift          |                          |

**Figure 3-4. Platform Control Console**



### 5. Power/Emergency Stop Switch

A two-position red mushroom shaped switch furnishes power to Platform Controls when pulled out (on). When pushed in (off), power is shut off to the platform functions.



### 6. Start/Auxiliary Power

When pushed forward, the switch energizes the starter motor to start the engine.

The Auxiliary Power control switch energizes the electrically operated hydraulic pump. (Switch must be held on for duration of auxiliary pump use.)



The auxiliary pump functions to provide sufficient oil flow to operate the basic machine functions should the main pump or engine fail. The auxiliary pump will operate tower boom lift, tower telescope, main boom lift, main telescope and swing.

### 7. Fuel Select (Dual Fuel Engine Only) (If Equipped)



Gasoline or liquid propane fuel may be selected by moving the switch to the appropriate position. It is unnecessary to purge the fuel system before switching fuels, so there is no waiting period when switching fuels while the engine is running.

### 8. Drive Orientation Override



When the boom is swung over the rear tires or further in either direction, the Drive Orientation indicator will illuminate when the drive function is selected. Push and release the switch, and within 3 seconds move the Drive/Steer control to activate drive or steer. Before driving, locate the black/white orientation arrows on both the chassis and the platform controls. Move the drive controls in a direction matching the directional arrows.

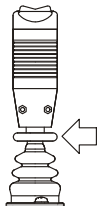
## SECTION 3 - MACHINE CONTROLS AND INDICATORS

**NOTE:** Lift, Swing, and Drive control levers are spring-loaded and will automatically return to neutral (off) position when released.

### **⚠ WARNING**

**TO AVOID SERIOUS INJURY, DO NOT OPERATE MACHINE IF ANY CONTROL LEVERS OR TOGGLE SWITCHES CONTROLLING PLATFORM MOVEMENT DO NOT RETURN TO THE OFF OR NEUTRAL POSITION WHEN RELEASED.**

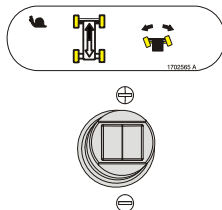
**NOTE:** To operate the Drive joystick, pull up on the lock-ring below the handle.



**NOTE:** The Drive joystick is spring loaded and will automatically return to neutral (off) position when released.

#### 9. Drive/Steer

Push forward to drive forward, pull back to drive in reverse. Steering is accomplished via a thumb-activated rocker switch on the end of the steer handle.



#### 10. Main Boom Telescope

Provides extension and retraction of the main boom.



#### 11. Lights (If Equipped)

This switch operates control console panel lights and head lights if the machine is so equipped. The ignition switch does not have to be on to operate the lights, so care must be taken to avoid draining the battery if left unattended. The master switch and / or the ignition switch at the ground control will turn off power to all lights.



#### 12. Jib (If Equipped)

Push forward to lift up, pull back to lift down. Variable lift speed is using the Function Speed Control.



#### 13. Soft Touch Override Switch (If equipped)

This switch enables the functions that were cut out by the Soft Touch system to operate again at creep speed, allowing the operator to move the platform away from the obstacle that caused the shut-down situation.



## SECTION 3 - MACHINE CONTROLS AND INDICATORS

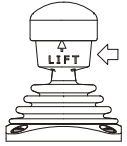
### 14. Soft Touch Indicator (If Equipped)

Indicates the Soft Touch bumper is against an object. All controls are cut out until the override button is pushed, at which time controls are active in the Creep Mode.



**NOTE:** To operate the Main Boom Lift/Swing joystick, pull up on the locking ring below the handle.

**NOTE:** The Main Boom Lift/Swing joystick is spring loaded and will automatically return to neutral (off) position when released.



### 15. Platform Rotate

Provides rotation of the platform when positioned to the right or left.



### **CAUTION**

**DO NOT OPERATE MACHINE IF DRIVE SPEED /TORQUE SELECT OR FUNCTION SPEED SWITCHES OPERATE WHEN BOOM IS ABOVE HORIZONTAL.**

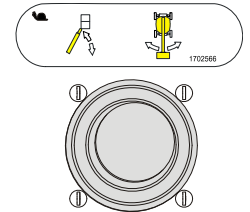
### 16. Function Speed Control

This control affects the speed of telescope and platform rotate. Turning the knob all the way counterclockwise until it clicks puts drive, main lift and swing into creep mode.



### 17. Main Lift/Swing Controller

Provides main lift and swing. Push forward to lift up, pull backward to boom down. Move right to swing right, move left to swing left. Moving the joystick activates switches to provide the functions selected.



### Platform Control Indicator Panel

(See Figure 3-5., Platform Control Indicator Panel)

#### 1. Tilt Alarm Warning Light and Alarm

This illuminator indicates that the chassis is on a slope. An alarm will also sound when the chassis is on a slope and the boom is above horizontal. If lit when boom is raised or extended, retract and lower to below horizontal then reposition machine so that it is level before continuing operation. If the boom is above horizontal and the machine is on a slope, the tilt alarm warning light will illuminate and an alarm will sound and CREEP is automatically activated.



#### **⚠ WARNING**

**IF TILT WARNING LIGHT IS ILLUMINATED WHEN BOOM IS RAISED OR EXTENDED, RETRACT AND LOWER TO BELOW HORIZONTAL THEN REPOSITION MACHINE SO THAT IT IS LEVEL BEFORE EXTENDING BOOM OR RAISING BOOM ABOVE HORIZONTAL.**

**NOTE:** *When the tilt sensor alarm is activated the Drive function will be disabled if the boom is elevated above horizontal.*

#### 2. Platform Overload (If equipped)

Indicates the platform has been overloaded.

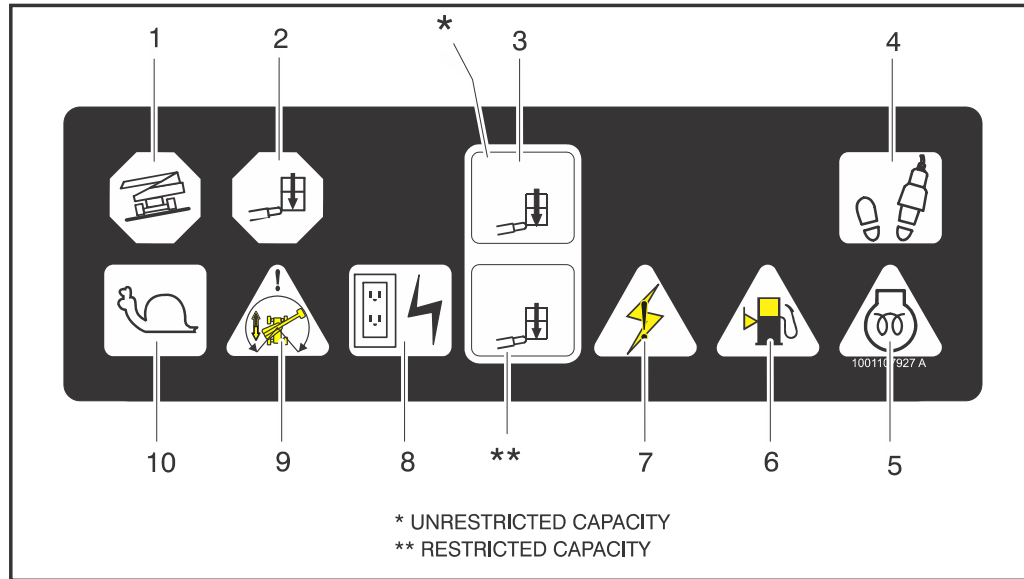


#### 3. Capacity Indicator

Indicates the maximum platform capacity for the current position of the platform. Restricted capacities are permitted at restricted platform positions (shorter boom lengths and higher boom angles).

**NOTE:** *Refer to the capacity decals on the machine for restricted and unrestricted platform capacities.*





- |             |                    |                      |
|-------------|--------------------|----------------------|
| 1. Tilt     | 5. Glow Plug       | 8. AC Generator      |
| 2. Overload | 6. Low Fuel        | 9. Drive Orientation |
| 3. Capacity | 7. System Distress | 10. Creep            |
| 4. Enable   |                    |                      |

Figure 3-5. Platform Control Indicator Panel

## SECTION 3 - MACHINE CONTROLS AND INDICATORS

### 4. Footswitch/Enable Indicator



To operate any function, the footswitch must be depressed and the function selected within seven seconds. The enable indicator shows that the controls are enabled. If a function is not selected within seven seconds, or if a seven second lapse between ending one function and beginning the next function, the enable light will go out and the footswitch must be released and depressed again to enable the controls.

Releasing the footswitch removes power from all controls and applies the drive brakes.

#### **⚠ WARNING**

**TO AVOID SERIOUS INJURY, DO NOT REMOVE, MODIFY OR DISABLE THE FOOTSWITCH BY BLOCKING OR ANY OTHER MEANS.**

#### **⚠ WARNING**

**FOOTSWITCH MUST BE ADJUSTED IF FUNCTIONS ACTIVATE WHEN SWITCH ONLY OPERATES WITHIN LAST 1/4" OF TRAVEL, TOP OR BOTTOM.**

### 5. Glow Plug/Wait to Start Indicator



Indicates the glow plugs are operating. After turning on ignition, wait until light goes out before cranking engine.

### 6. Low Fuel Indicator (Yellow)



Indicates the fuel tank is 1/8 full or less. When the light first turns on, there are approximately four usable gallons of fuel remaining.

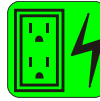
### 7. System Distress Indicator



The light indicates that the JLG Control System has detected an abnormal condition and a Diagnostic Trouble Code has been set in the system memory. Refer to the Service Manual for instructions concerning the trouble codes and trouble code retrieval.

### 8. AC Generator (If Equipped)

Indicates the generator is in operation.



### 9. Drive Orientation Indicator

When the boom is swung beyond the rear drive tires or further in either direction, the Drive Orientation indicator will illuminate when the drive function is selected. This is a signal for the operator to verify that the drive control is being operated in the proper direction (i.e. controls reversed situations).



### 10. Creep Speed Indicator

When the Function Speed Control is turned to the creep position, the indicator acts as a reminder that all functions are set to the slowest speed.



**SECTION 3 - MACHINE CONTROLS AND INDICATORS**

---



**NOTES:**

---

---

---

---

---

---

---

---

---

---

---

---

---

---

---

---

---

---

---

---

---

---

---

---

---

---

---

---

---

---

---

---

---

---

---

---

---

---

---

---

---

---

---

---



## **SECTION 4. MACHINE OPERATION**

### **4.1 DESCRIPTION**

This machine is a self-propelled hydraulic personnel lift equipped with a work platform on the end of an elevating and rotating boom.

The primary operator control station is in the platform. From this control station, the operator can drive and steer the machine in both forward and reverse directions. The operator can raise or lower the main or tower boom or swing the boom to the left or right. Standard boom swing is 360 degree continuous left and right of the stowed position. The machine has a Ground Control Station which will override the Platform Control Station. Ground Controls operate Boom Lift and Swing, and are to be used in an emergency to lower the platform to the ground should the operator in the platform be unable to do so.

### **4.2 OPERATING CHARACTERISTICS AND LIMITATIONS**

#### **Capacities**

The boom can be raised above horizontal with or without any load in platform, if:

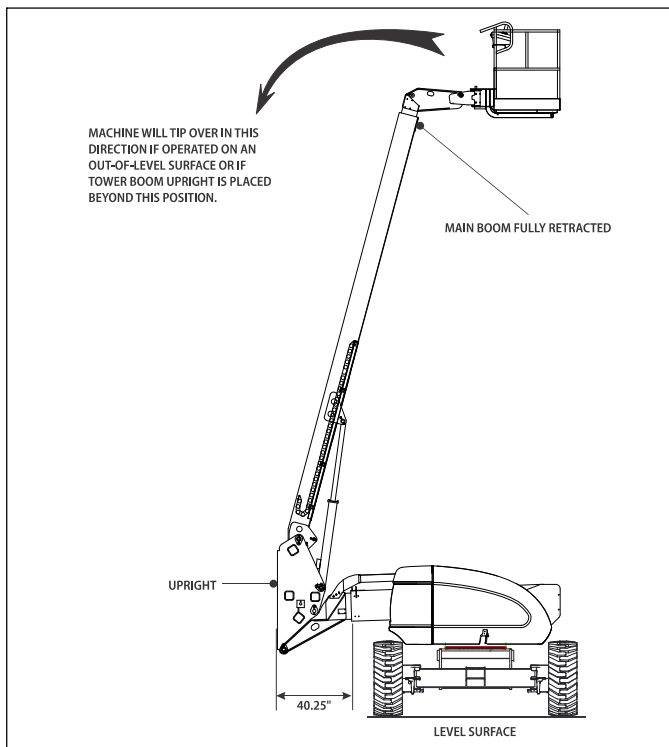
1. Machine is positioned on a smooth, firm and level surface.
2. Load is within manufacturer's rated capacity.
3. All machine systems are functioning properly.
4. Proper tire pressure.
5. Machine is as originally equipped from JLG.

### Stability

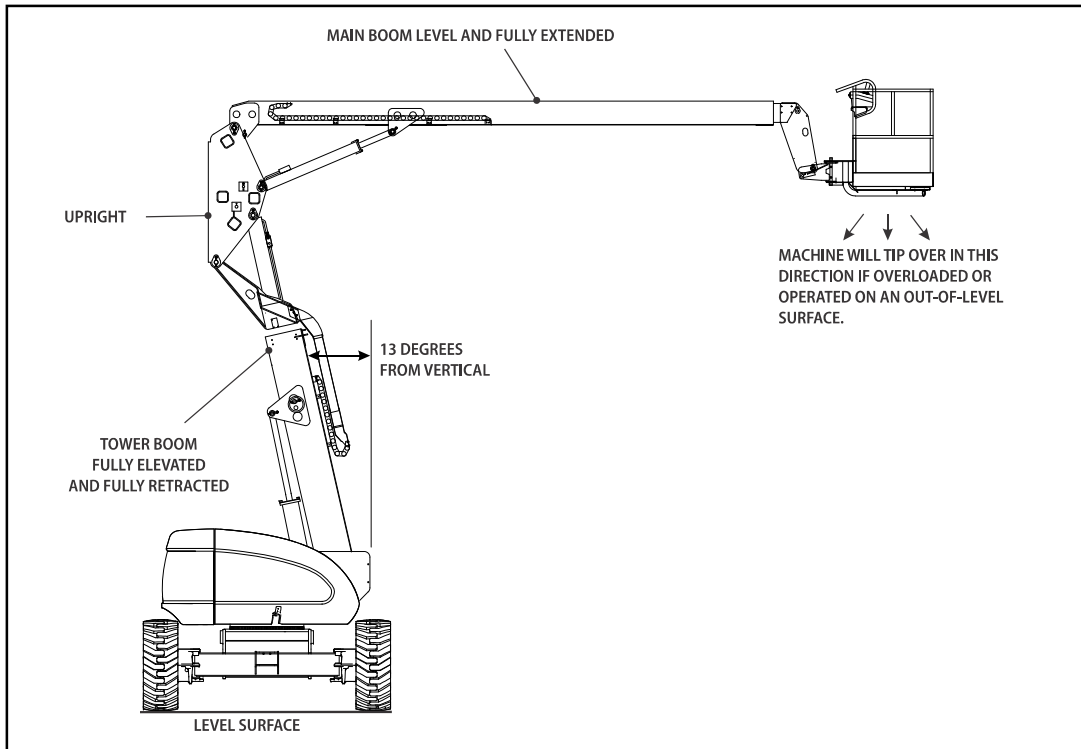
Machine stability is based on two positions which are called FORWARD and BACKWARD stability. The machines position of least FORWARD stability is shown in Figure 4-2., Position of Least Forward Stability, and its position of least BACKWARD stability is shown in Figure 4-1., Position of Least Backward Stability.

#### **⚠ WARNING**

**TO AVOID FORWARD OR BACKWARD TIPPING, DO NOT OVERLOAD MACHINE OR OPERATE THE MACHINE ON AN OUT-OF-LEVEL SURFACE.**



**Figure 4-1. Position of Least Backward Stability**

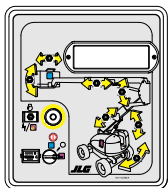


**Figure 4-2. Position of Least Forward Stability**

## SECTION 4 - MACHINE OPERATION

### 4.3 ENGINE OPERATION

**NOTE:** Initial starting should always be performed from the Ground Control station.



#### Starting Procedure

#### **CAUTION**

IF ENGINE FAILS TO START PROMPTLY, DO NOT CRANK FOR AN EXTENDED TIME. SHOULD ENGINE FAIL TO START AGAIN, ALLOW STARTER TO "COOL OFF" FOR 2-3 MINUTES. IF ENGINE FAILS AFTER SEVERAL ATTEMPTS, REFER TO ENGINE MAINTENANCE MANUAL.

**NOTE:** Diesel engines only: After turning on ignition, operator must wait until glow plug indicator light goes out before cranking engine.

1. Turn key of Platform/Ground Select switch to Ground.



2. Pull the Power/Emergency Stop switch to On.



3. Push the Engine Start switch until engine starts.



#### **CAUTION**

ALLOW ENGINE TO WARM-UP FOR A FEW MINUTES AT LOW SPEED BEFORE APPLYING ANY LOAD.

4. After engine has had sufficient time to warm up, push in the Power/Emergency Stop switch and shut engine off.



5. Turn Platform/Ground Select switch to Platform.



6. From Platform, pull Power/Emergency Stop switch out.



7. Push the Engine Start switch until engine starts.



## Fuel Reserve / Shut-Off System

**NOTE:** Reference the Service and Maintenance Manual along with a qualified JLG Mechanic to verify your machine setup.

**NOTE:** Footswitch must be in released (up) position before starter will operate. If starter operates with footswitch in the depressed position, DO NOT OPERATE MACHINE.

## Shutdown Procedure

### CAUTION

**IF AN ENGINE MALFUNCTION CAUSES AN UNSCHEDULED SHUTDOWN, DETERMINE THE CAUSE AND CORRECT IT BEFORE RESTARTING THE ENGINE.**

1. Remove all load and allow engine to operate at low speed for 3-5 minutes; this allows further reduction of internal engine temperature.
2. Push Power/Emergency Stop switch in.

3. Turn Platform/Ground Select switch to Off.

Refer to Engine Manufacturer's manual for detailed information.



The Fuel Shutoff System monitors the fuel in the tank and senses when the fuel level is getting low. The JLG Control System automatically shuts the engine down before the fuel tank is emptied unless the machine is set up for Engine Restart.

If fuel level reaches the Empty range, the Low Fuel light will begin to flash once a second and there will be approximately 60 minutes of engine run time left. If the system is in this condition and automatically shuts down the engine or if the operator manually shuts down the engine before the 60 minute run time is complete, the Low Fuel light will flash 10 times a second and the engine will react according to machine setup. Setup options are as follows:



- Engine One Restart - When the engine shuts down, the operator will be permitted to cycle power and restart the engine once with approximately 2 minutes of run time. After the 2 minute run time is complete or if the engine is shut down by the operator prior to the completion of the 2 minute run time, it cannot be restarted until fuel is added to the tank.

- Engine Restart - When the engine shuts down, the operator will be permitted to cycle power and restart the engine for approximately 2 minutes of run time. After the 2 minutes of run time is complete, the operator may cycle power and restart the engine for an additional 2 minutes of run time. The operator can repeat this process until there is no more fuel available.

### **NOTICE**

**CONTACT A QUALIFIED JLG MECHANIC IF THE MACHINE NEEDS RESTARTED AFTER NO MORE FUEL IS AVAILABLE.**

- Engine Stop - When the engine shuts down, no restarts will be permitted until fuel is added to the tank.

## 4.4 TRAVELING (DRIVING)

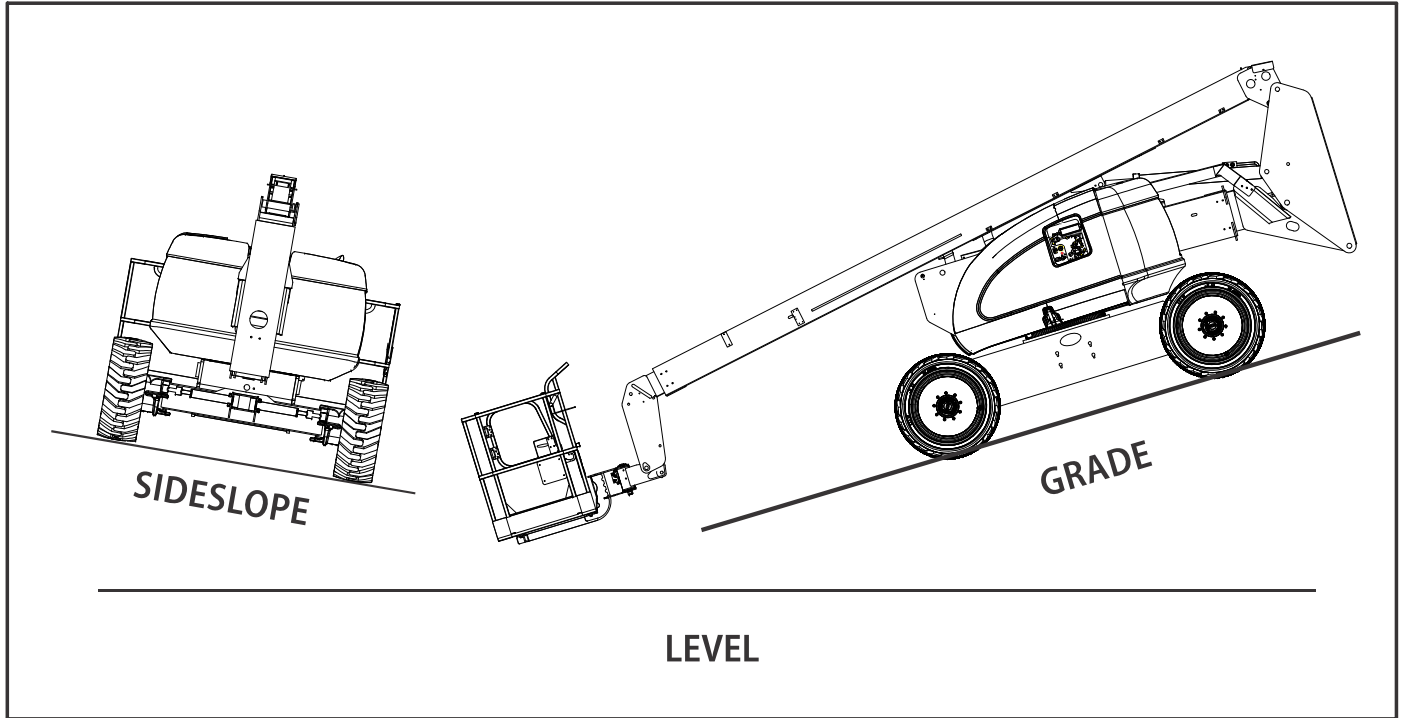
*See Figure 4-3., Grade and Sideslope*

**NOTE:** *Refer to the Operating Specifications table for Gradeability and Sideslope ratings.*

*All ratings for Gradeability and Sideslope are based upon the machine's boom being in the stowed position, fully lowered, and retracted.*

Traveling is limited by two factors:

1. Gradeability, which is the percent of grade of the incline the machine can climb.
2. Sideslope, which is the angle of the slope the machine can be driven across.



**Figure 4-3. Grade and Sideslope**

### **⚠ WARNING**

**DO NOT DRIVE WITH BOOM ABOVE HORIZONTAL EXCEPT ON A SMOOTH, FIRM AND LEVEL SURFACE.**

**TO AVOID LOSS OF TRAVEL CONTROL OR "TIP OVER", DO NOT DRIVE MACHINE ON GRADES EXCEEDING THOSE SPECIFIED ON THE SERIAL NUMBER PLATE.**

**BE SURE THE TURNABLE LOCK IS ENGAGED BEFORE ANY EXTENDED TRAVELING.**

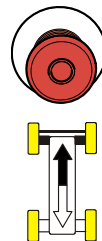
**DO NOT DRIVE ON SIDESLOPES WHICH EXCEED 5 DEGREES.**

**USE EXTREME CAUTION WHEN DRIVING IN REVERSE AND AT ALL TIMES WHEN THE PLATFORM IS ELEVATED.**

**BEFORE DRIVING, MAKE SURE BOOM IS POSITIONED OVER REAR DRIVE AXLE. IF BOOM IS OVER FRONT WHEELS, STEER AND DRIVE CONTROLS WILL BE REVERSED.**

## Traveling Forward and Reverse

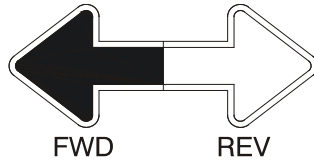
1. At Platform Controls, pull out Emergency Stop switch and activate footswitch.
2. Position Drive controller to FORWARD or REVERSE as desired.



This machine is equipped with a Drive Orientation Indicator. The yellow light on the platform control console indicates that the boom is swung beyond the rear drive tires and the machine may Drive/Steer in the opposite direction from the movement of the controls. If the indicator is illuminated, operate the Drive function in the following manner:



1. Match the black and white direction arrows on both platform control panel and the chassis to determine the direction the machine will travel.



2. Push and release the Drive Orientation Override switch. Within 3 seconds, slowly move the Drive control toward the arrow matching the intended direction of machine travel. The indicator light will flash during the 3 second interval until the drive function is selected.



## 4.5 STEERING

Position thumb switch on Drive/Steer controller to Right for steering right, or to Left for steering left.



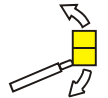
## 4.6 PLATFORM

### Platform Level Adjustment



**ONLY USE THE PLATFORM LEVELING OVERRIDE FUNCTION FOR SLIGHT LEVELING OF THE PLATFORM. INCORRECT USE COULD CAUSE THE LOAD/OCCUPANTS TO SHIFT OR FALL. FAILURE TO DO SO COULD RESULT IN DEATH OR SERIOUS INJURY.**

To Level Up or Down - Position the Platform/Level control switch Up or Down and hold until the platform is level.



### Platform Rotation

To rotate the platform to the left or right, use the Platform Rotate control switch to select the direction and hold until desired position is reached.



### 4.7 BOOM

#### **⚠ WARNING**

DO NOT SWING OR RAISE BOOM ABOVE HORIZONTAL WHEN MACHINE IS OUT OF LEVEL.

DO NOT DEPEND ON TILT ALARM AS A LEVEL INDICATOR FOR THE CHASSIS.

TO AVOID TIP OVER, LOWER PLATFORM TO GROUND LEVEL. THEN DRIVE MACHINE TO A LEVEL SURFACE BEFORE RAISING BOOM.

TO AVOID SERIOUS INJURY, DO NOT OPERATE MACHINE IF ANY CONTROL LEVER OR TOGGLE SWITCH CONTROLLING PLATFORM MOVEMENT DOES NOT RETURN TO THE 'OFF' OR NEUTRAL POSITION WHEN RELEASED.

IF THE PLATFORM DOES NOT STOP WHEN A CONTROL SWITCH OR LEVER IS RELEASED, REMOVE FOOT FROM FOOTSWITCH OR USE EMERGENCY STOP SWITCH TO STOP THE MACHINE.

### Swinging the Boom

To swing boom, use Swing control switch to select Right or Left direction.



#### **NOTICE**

WHEN SWINGING THE BOOM MAKE SURE THERE IS AMPLE ROOM FOR THE BOOM TO CLEAR SURROUNDING WALLS, PARTITIONS AND EQUIPMENT.

**NOTE:** *On CE Market machines, when boom functions are being operated there is an interlock that prevents the use of Drive and Steer functions.*

## Raising and Lowering the Tower Boom

This machine has two controls for the tower boom (two toggle switches), one controls tower lift, the other tower telescope. The switching system will sequence its Lift and Telescope functions as follows:

1. Sequence while raising the Tower Boom from the fully lowered position.

- a. The Tower Boom must be fully elevated “up” (approximately 13 degrees from vertical) before the Tower Boom can be extended from the fully retracted position.



- b. The Tower Telescope “out” or “in” will only be operable when the Tower Boom is fully elevated “up”.



2. Sequence while lowering the Tower Boom from the fully elevated “up” position.

- a. Operate Tower Telescope “in” until Tower Boom is fully retracted. (Tower must not lift “down until boom is telescoped “in” or “up” fully.



- b. The Tower lift “down” will only operate when the Tower Boom is fully retracted.



### **⚠ WARNING**

**TO AVOID TILTING MACHINE IF TOWER BOOM SWITCHING MALFUNCTIONS:**

- LOWER PLATFORM TO GROUND USING MAIN BOOM LIFT AND TELESCOPE FUNCTIONS.
- HAVE CONDITION CORRECTED BY A CERTIFIED JLG SERVICE TECHNICIAN BEFORE CONTINUING USE OF MACHINE.

## SECTION 4 - MACHINE OPERATION

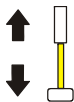
### Raising and Lowering the Main Boom

To raise or lower the Main Boom, position the Main Boom Lift switch to Up or Down until the desired height is reached.



### Telescoping the Main Boom

To extend or retract the main boom, use the Main Telescope Control Switch to select In or Out movement.



## 4.8 RE-SYNCHRONIZE THE LOWER LIFT CYLINDER

### Level Override Valve

A pull type control valve allows the operator to adjust the tower lift cylinder and the upright cylinder if the upright cylinder is not fully retracted when boom is in the stowed position. This valve is located in the engine compartment area.



To Operate:

1. Pull the red knob
2. Using the ground control raise the lower boom 6 feet.
3. Release the knob.
4. Fully lower the boom.
5. Repeat if necessary.

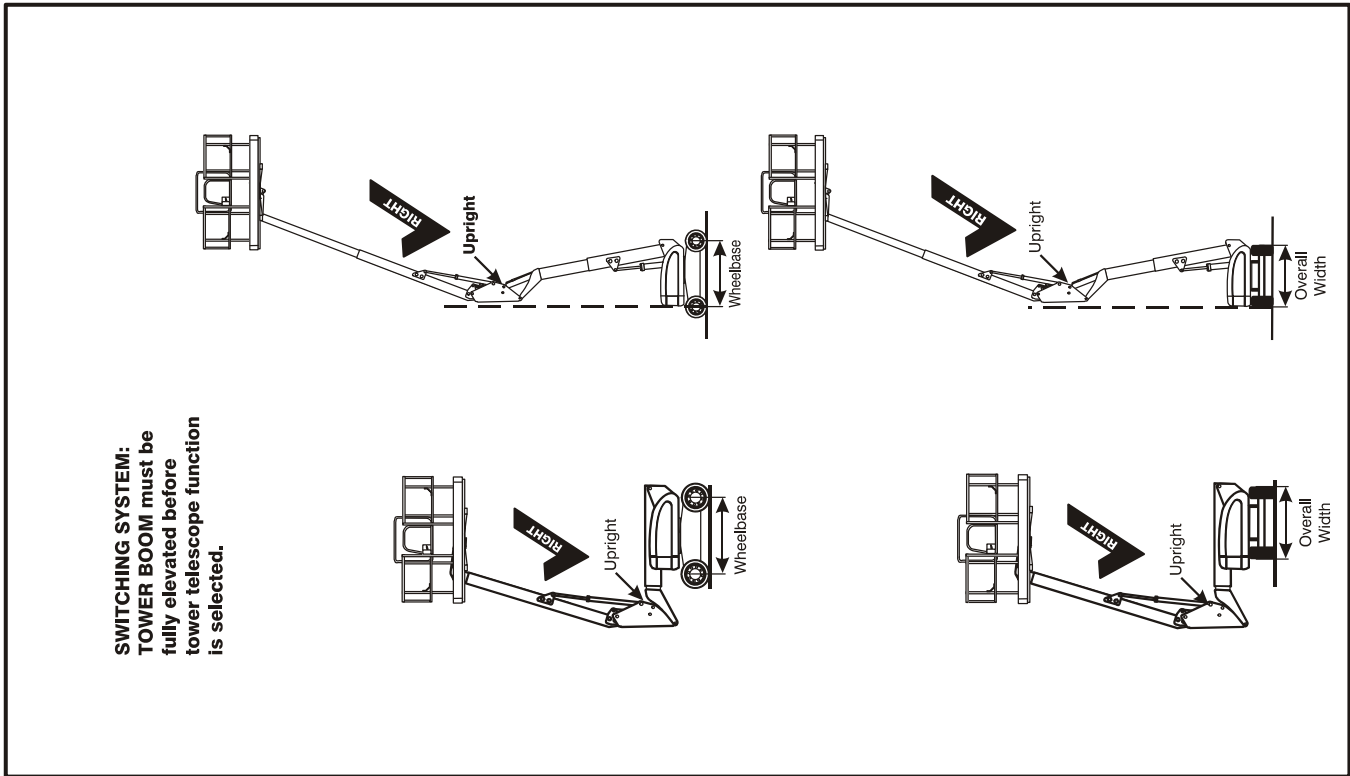


Figure 4-4. Boom Upright Positioning - Sheet 1 of 2

**⚠ WARNING**

TO AVOID TIPPING OVER IF THIS OCCURS:

- LOWER PLATFORM TO GROUND VIA MAIN BOOM LIFT AND TELESCOPE FUNCTIONS. HAVE CONDITION CORRECTED BY A CERTIFIED JLG SERVICE TECHNICIAN BEFORE CONTINUING USE OF MACHINE.

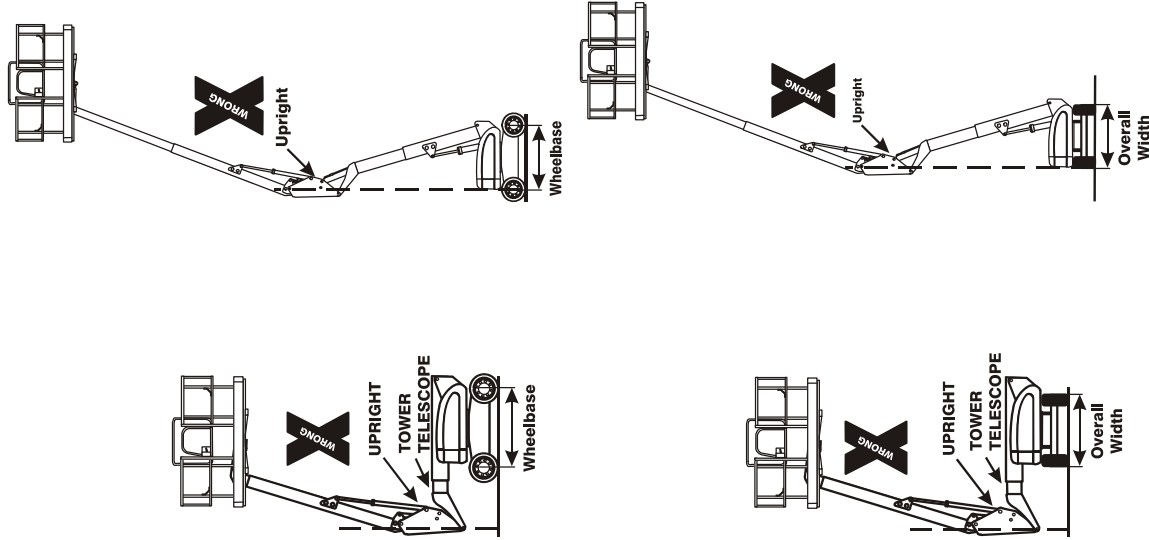


Figure 4-5. Boom Upright Positioning - Sheet 2 of 2

## **4.9 SHUT DOWN AND PARK**

1. Drive machine to a protected area.
2. Assure boom is fully retracted and lowered over rear (Drive) axle; all access panels and doors closed and secured.
3. Remove all load and allow engine to operate 3-5 minutes at idle to permit reduction of engine internal temperatures.
4. At Ground Controls, turn Key Select switch to (center) Off Position, Power/Emergency Stop switch (down) to Off. Remove key.
5. Cover Platform Control console to protect instruction placards, warning decals and operating controls from hostile environment.

## **4.10 OSCILLATING AXLE LOCKOUT TEST (IF EQUIPPED)**

### **NOTICE**

**LOCKOUT SYSTEM TEST MUST BE PERFORMED QUARTERLY, ANY TIME A SYSTEM COMPONENT IS REPLACED, OR WHEN IMPROPER SYSTEM OPERATION IS SUSPECTED.**

Refer to Section 6.5, Oscillating Axle Lockout Test (If Equipped) for procedure.

## **4.11 STEER/TOW SELECTOR (IF EQUIPPED)**

### **WARNING**

**DO NOT ATTEMPT TO TOW MACHINE UNLESS EQUIPPED WITH COMPLETE TOW PACKAGE FROM MANUFACTURER.**

A push-pull type selector valve located adjacent to the steer cylinder and linkage regulates oil flow in the steer circuit for steering and towing. When steering the unit the valve knob is pushed IN. When towing the unit the valve knob is pulled OUT to the float position.

## **4.12 TOWING (IF EQUIPPED)**

### **⚠ WARNING**

**RUNAWAY VEHICLE/MACHINE HAZARD. MACHINE HAS NO TOWING BRAKES. TOWING VEHICLE MUST BE ABLE TO CONTROL MACHINE AT ALL TIMES. ON-HIGHWAY TOWING NOT PERMITTED. FAILURE TO FOLLOW INSTRUCTIONS COULD CAUSE SERIOUS INJURY OR DEATH.**

**MAXIMUM TOWING SPEED 8 M.P.H. (13 K.M.H.)**

**MAXIMUM TOWING GRADE 25%.**

Prior to towing the machine, complete the following:

### **⚠ CAUTION**

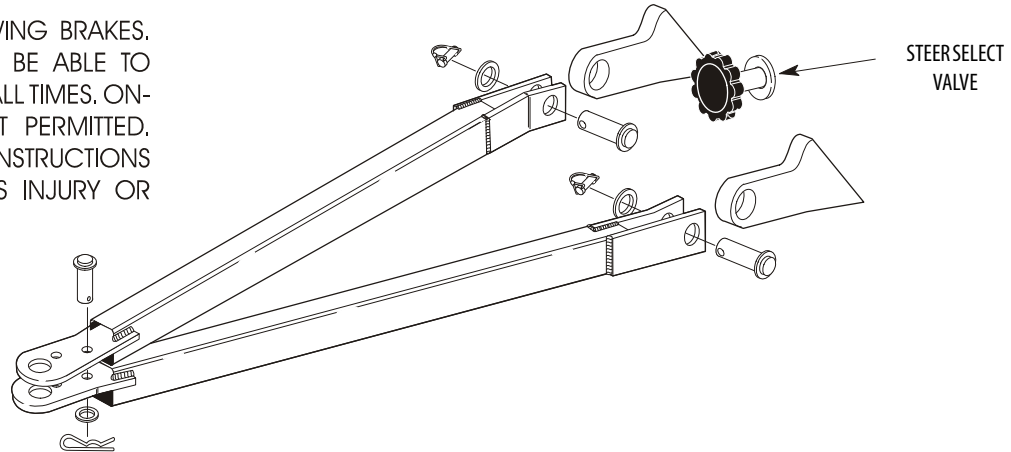
**DO NOT TOW MACHINE WITH ENGINE OPERATING OR DRIVE HUBS ENGAGED.**

- 1.** Retract, lower and position boom over rear drive wheels in line with direction of travel; lock turntable.
- 2.** Connect tow bar to front of frame with attach pins, and tow bar to towing vehicle.



**⚠ WARNING****RUNAWAY VEHICLE/  
MACHINE HAZARD**

MACHINE HAS NO TOWING BRAKES. TOWING VEHICLE MUST BE ABLE TO CONTROL MACHINE AT ALL TIMES. ON-HIGHWAY TOWING NOT PERMITTED. FAILURE TO FOLLOW INSTRUCTIONS COULD CAUSE SERIOUS INJURY OR DEATH.

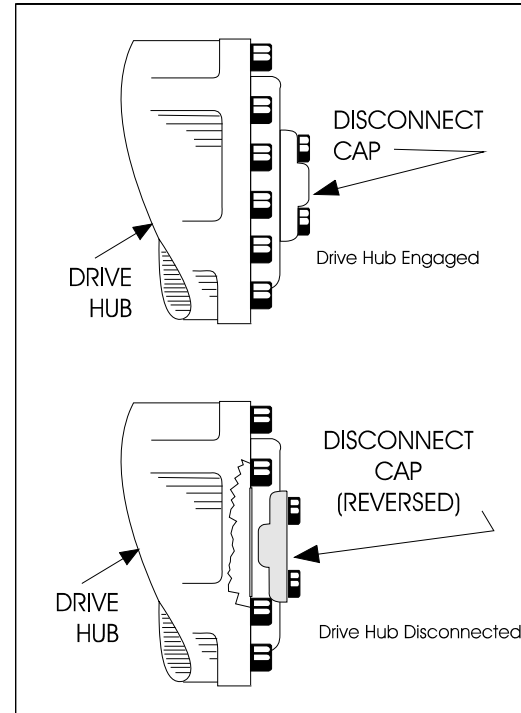
**Figure 4-6. Towbar Connecting Points**

## SECTION 4 - MACHINE OPERATION

3. Disconnect drive hubs by inverting disconnect cap. Refer to Figure 4-7., Drive Disconnect Hub.
4. Actuate steer/tow selector valve for towing; pull valve knob OUT to float position. (This opens the steer circuit to reservoir, allowing the steer cylinder rod free travel.) The machine is now in the towing mode.

After towing the machine, complete the following:

1. Actuate steer/tow selector valve for steering; push valve knob IN to the actuated position.
2. Reconnect drive hubs by inverting disconnect cap.
3. Disconnect tow bar from steering hitch and from towing vehicle. The machine is now in the driving mode.



**Figure 4-7. Drive Disconnect Hub**

**4.13 AUXILIARY POWER**

**⚠ CAUTION**

**WHEN OPERATING ON AUXILIARY POWER, DO NOT OPERATE MORE THAN ONE FUNCTION AT A TIME. (SIMULTANEOUS OPERATION CAN OVERLOAD THE 12-VOLT AUXILIARY PUMP MOTOR.)**

A toggle type auxiliary power control switch is located on the platform control station and another is located on the ground control station. Operation of either switch turns on the electrically driven auxiliary hydraulic pump. This should be used in case of failure of the main power plant. The auxiliary pump will operate boom lift, telescope and swing. To activate auxiliary power:

**Activating from the Platform Control Station**

1. Position Platform/Ground Select Key Switch to Platform.
2. Position Power/Emergency Stop switch to On.
3. Depress and hold footswitch.



4. Position Auxiliary Power switch to On and hold.
5. Operate appropriate control switch, lever or controller for desired function and hold.
6. Release Auxiliary Power switch, selected control switch, lever or controller, and footswitch.
7. Position Power/Emergency Stop switch to Off.



**Activating from the Ground Control Station**

1. Position Platform/Ground Select Key Switch to Ground.
2. Position Power/Emergency Stop switch to On.
3. Position Auxiliary Power switch to On and hold.



## SECTION 4 - MACHINE OPERATION

4. Operate appropriate control switch or controller for desired function and hold.
5. Release Auxiliary Power switch, and appropriate control switch or controller.
6. Position Power/Emergency Stop switch to Off.



### 4.14 DUAL FUEL SYSTEM (GAS ENGINE ONLY)

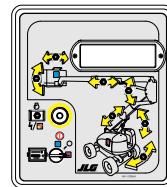
The dual fuel system enables the standard gasoline engine to run on either gasoline or LP gas.

#### CAUTION

IT IS POSSIBLE TO SWITCH FROM ONE FUEL SOURCE TO THE OTHER WITHOUT ALLOWING THE ENGINE TO STOP. EXTREME CARE MUST BE TAKEN AND THE FOLLOWING INSTRUCTIONS MUST BE FOLLOWED.

### Changing From Gasoline to LP Gas

1. Start engine from Ground Control Station.



2. Open hand valve on LP gas supply tank by turning counter-clockwise.
3. While engine is operating on Gasoline under a no-load condition, place Fuel Select switch at Platform Control to LP position.



### Changing From LP Gas to Gasoline

1. With engine operating on LP under a no-load condition, position Fuel Select switch at Platform Control Station to Gasoline position.
2. Close hand valve on LP gas supply tank by turning clockwise.



## **4.15 TIE DOWN AND LIFTING**

When transporting machine, boom must be in the stowed mode with turntable lock pin engaged and machine securely tied down to truck or trailer deck. Four tie down eyes are provided in the frame slab, one at each corner of the machine.

If it becomes necessary to lift the machine using an overhead or mobile crane, it is very important that the lifting devices are attached only to the designated lifting eyes, and that the turntable lock pin is engaged (See Figure 4-8., Lifting Chart).

**NOTE:** *Lifting eyes are provided at the front and rear in the frame slab. Each of the four chains or slings used for lifting machine must be adjusted individually so machine remains level when elevated.*

### **NOTICE**

**SECURE TURNTABLE WITH TURNTABLE LOCK BEFORE TRAVELING LONG DISTANCES OR HAULING MACHINE ON TRUCK/TRAILER.**

## SECTION 4 - MACHINE OPERATION

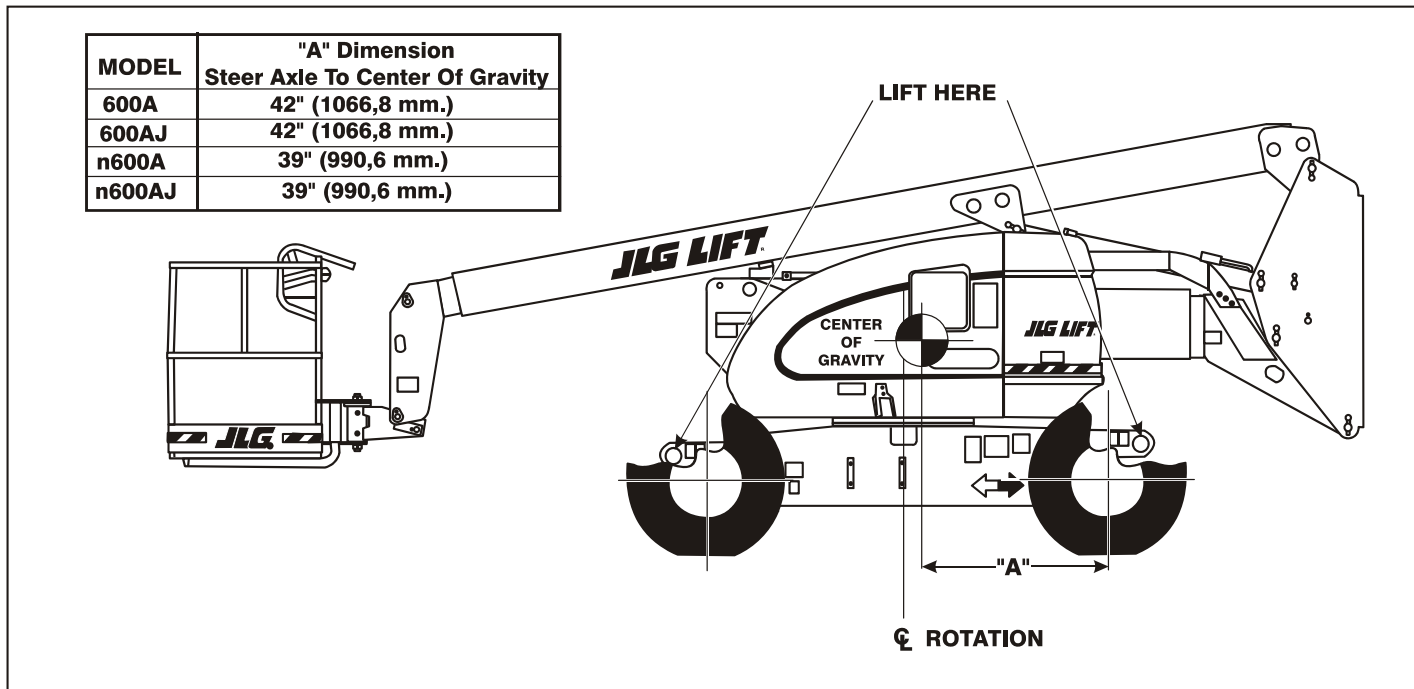


Figure 4-8. Lifting Chart

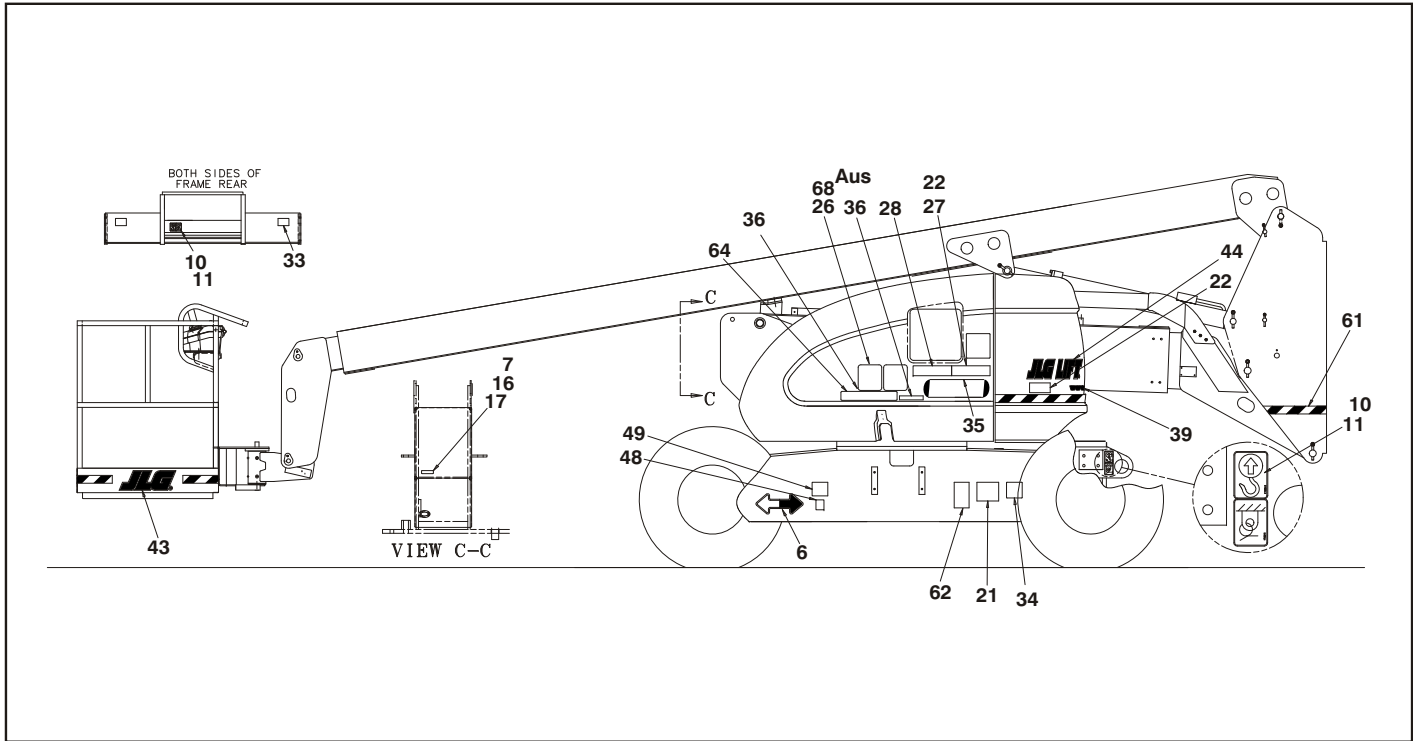


Figure 4-9. 600A & 600AJ Decal Installation - Sheet 1 of 4

## SECTION 4 - MACHINE OPERATION

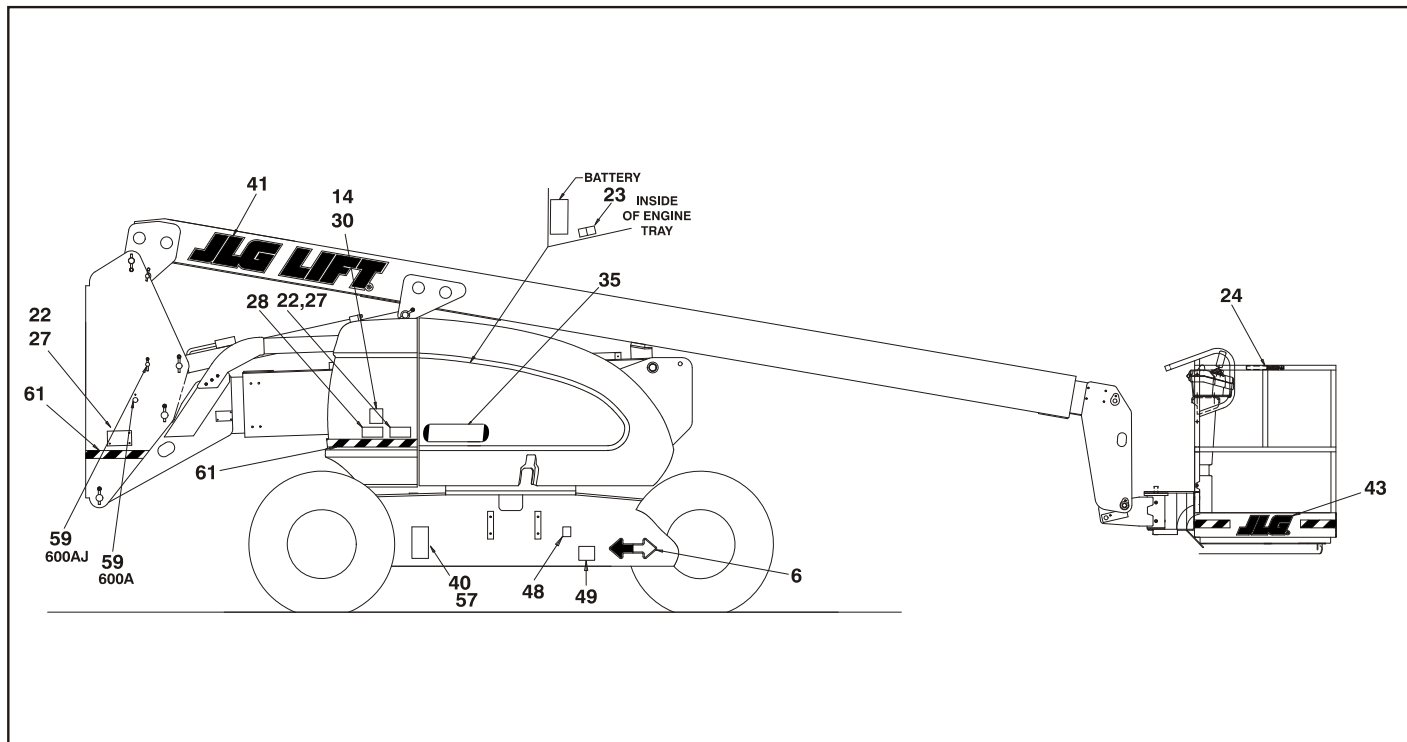
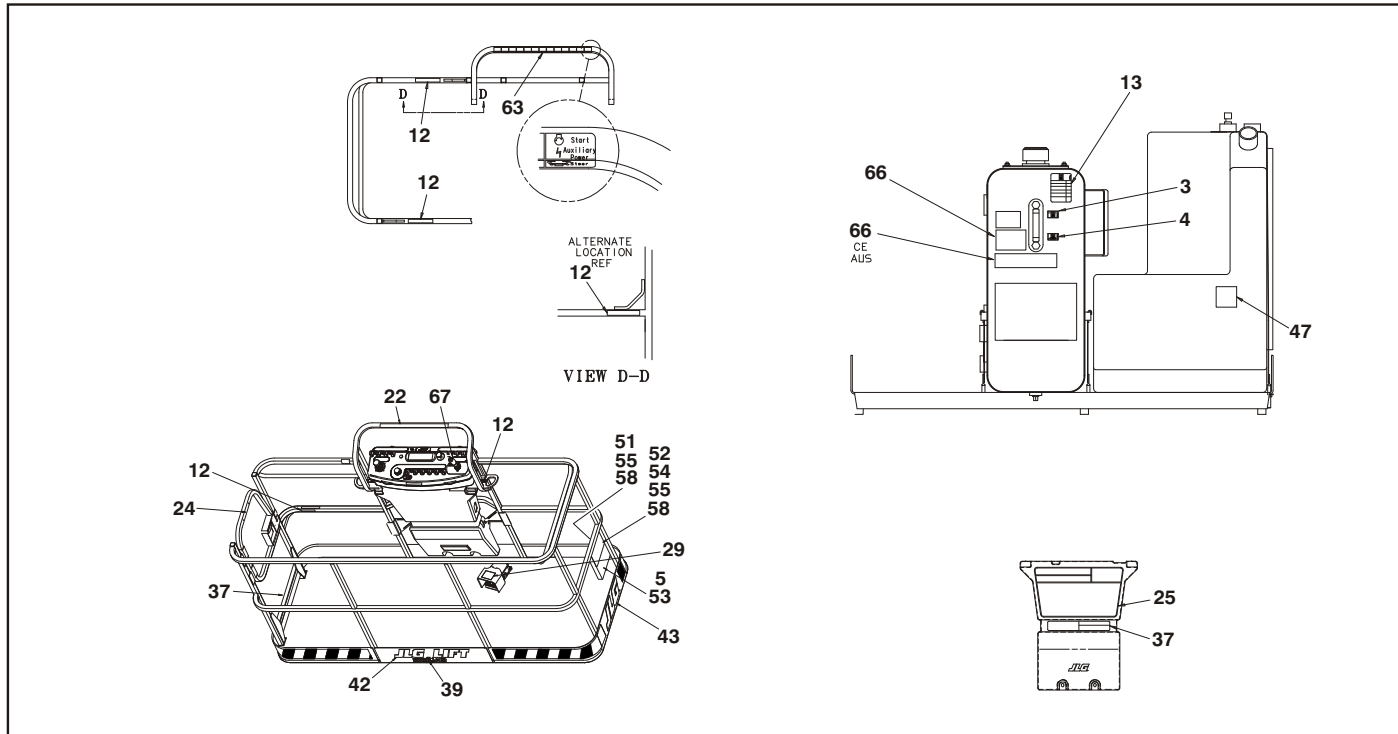
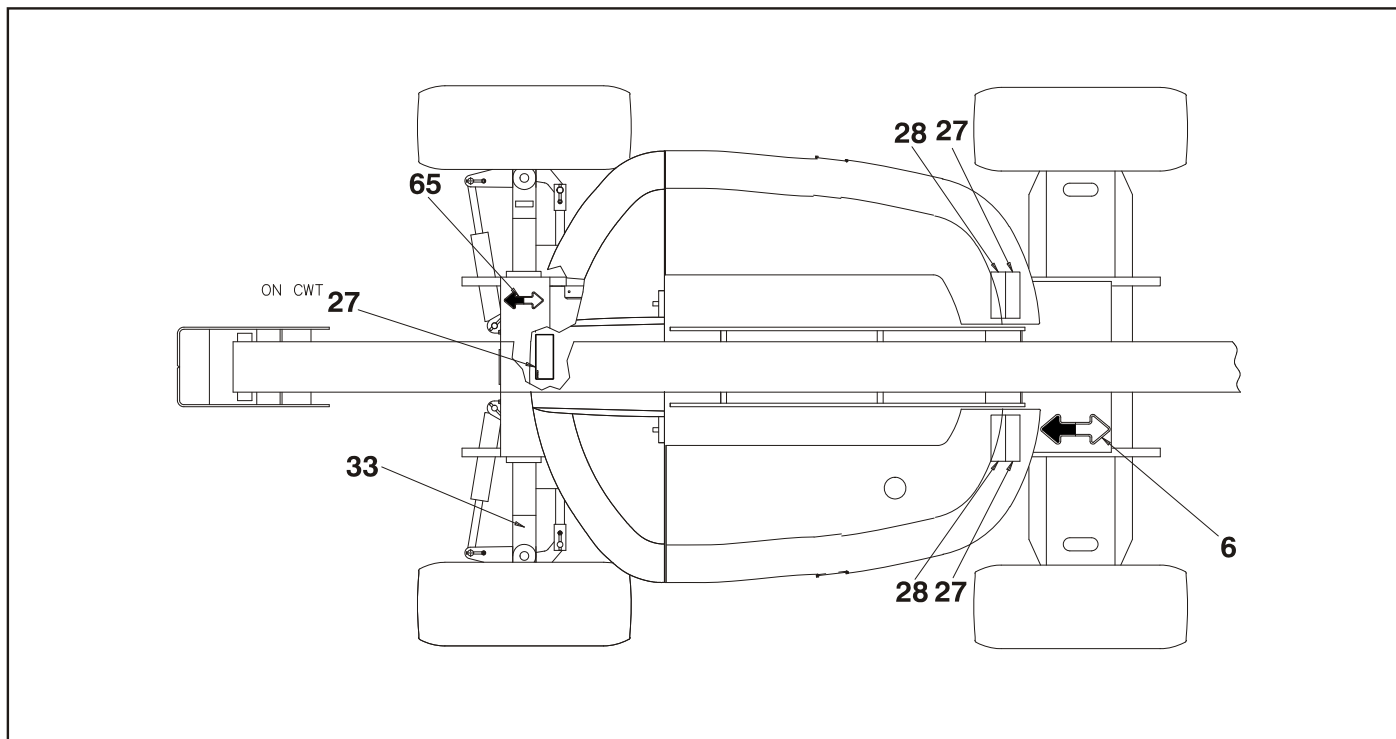


Figure 4-10. 600A & 600AJ Decal Installation - Sheet 2 of 4







**Figure 4-12. 600A & 600AJ Decal Installation - Sheet 4 of 4**

**Table 4-1. 600A Decal Legend**

<b>Item #</b>	<b>ANSI 1001156889-B</b>	<b>Canadian French 1001156985-B</b>	<b>CE/AUS 1001156987-B</b>	<b>Spanish 1001156972-B</b>	<b>Portuguese 1001156974-B</b>	<b>Japanese 1001156976-B</b>	<b>Chinese Simplified 1001156980-B</b>	<b>Chinese Traditional 1001156979-B</b>	<b>Korean 1001156983-B</b>
1	--	--	--	--	--	--	--	--	--
2	1701499	1701499	1701499	1701499	1701499	1701499	1701499	1701499	1701499
3	--	--	--	--	--	--	--	--	--
4	--	--	--	--	--	--	--	--	--
5	1701509	1701509	1701509	1701509	1701509	1701509	1701509	1701509	1701509
6	1701529	1701529	1701529	1701529	1701529	1701529	1701529	1701529	1701529
7	--	--	--	--	--	--	--	--	--
8	--	--	--	--	--	--	--	--	--
9	--	--	--	--	--	--	--	--	--
10	1703811	1703811	1703811	1703811	1703811	1703811	1703811	1703811	1703811
11	1703814	1703814	1703814	1703814	1703814	1703814	1703814	1703814	1703814
12	1704277	1704277	1704277	1704277	1704277	1704277	1704277	1704277	1704277
13	1704412	1704412	1704412	1704412	1704412	1704412	1704412	1704412	1704412
14	--	--	--	--	--	--	1705084	1705084	1705084
15	--	1705514	1705514	--	--	--	1705514	1705514	1705514
16	--	--	--	--	--	--	--	--	--
17	3251243	3251243	--	3251243	3251243	3251243	3251243	3251243	3251243

## SECTION 4 - MACHINE OPERATION

Table 4-1. 600A Decal Legend

Item #	ANSI 1001156889-B	Canadian French 1001156985-B	CE/AUS 1001156987-B	Spanish 1001156972-B	Portuguese 1001156974-B	Japanese 1001156976-B	Chinese Simplified 1001156980-B	Chinese Traditional 1001156979-B	Korean 1001156983-B
18	--	--	--	--	--	--	--	--	--
19	--	--	--	--	--	--	--	--	--
20	--	--	--	--	--	--	--	--	--
21	--	--	--	1704007	1705901	--	--	--	--
22	1703953	1703942	--	1703941	1705903	1703944	1001116845	1703943	1703945
23	--	--	--	--	--	--	--	--	--
24	1702868	1704000	--	1704001	1705967	--	1706968	1001116846	1705969
25	1703797	1703924	1705921	1703923	1705895	1703926	1001116847	1703925	1703927
26	1705336	1705347	1705822	1705917	1705896	1705344	1001116848	1001116849	1705345
27	1703804	1703948	1701518	1703947	1705898	1703950	1001116850	1703949	1703951
28	1703805	1703936	1705961	1703935	1705897	1703938	1703937	1001116851	1703939
29	3252347	1703984	1705828	1703983	1705902	1703980	1001116852	1703982	1703981
30	3251813	3251813	--	--	--	--	--	--	--
31	--	--	--	--	--	--	--	--	--
32	--	--	--	--	--	--	--	--	--
33	1001156891	1001156891	1001156891	1001156891	1001156891	1001156891	1001156891	1001156891	1001156891
34	--	1702631	--	--	--	--	1702631	1702631	1702631
35	1702818	1702818	1702818	1702818	1702818	1702818	1702818	1702818	1702819

Table 4-1. 600A Decal Legend

Item #	ANSI 1001156889-B	Canadian French 1001156985-B	CE/AUS 1001156987-B	Spanish 1001156972-B	Portuguese 1001156974-B	Japanese 1001156976-B	Chinese Simplified 1001156980-B	Chinese Traditional 1001156979-B	Korean 1001156983-B
36	1001121813	1001121815	1705978	1001121817	1001121819	1001121820	1001121824	1001121822	1001122201
37	1001121800	1001121802	1705978	1001121804	1001121806	1001121807	1001121811	1001121809	1001122200
38	--	--	--	--	--	--	--	--	--
39	1704885	1704885	1704885	1704885	1704885	1704885	1704885	1704885	1704885
40	1706948	1706948	--	--	1706948	1706948	--	--	--
41	--	--	--	--	--	--	--	--	--
42	--	--	--	--	--	--	--	--	--
43	--	--	--	--	--	--	--	--	--
44	--	--	--	--	--	--	--	--	--
45	--	--	--	--	--	--	--	--	--
46	--	--	--	--	--	--	--	--	--
47	--	--	--	--	--	--	--	--	--
48	--	--	--	--	--	--	--	--	--
49	--	--	--	--	--	--	--	--	--
50	--	--	--	--	--	--	--	--	--
51	--	--	--	--	--	--	--	--	--
52	--	--	--	--	--	--	--	--	--
53	--	--	--	--	--	--	--	--	--

## SECTION 4 - MACHINE OPERATION

Table 4-1. 600A Decal Legend

Item #	ANSI 1001156889-B	Canadian French 1001156985-B	CE/AUS 1001156987-B	Spanish 1001156972-B	Portuguese 1001156974-B	Japanese 1001156976-B	Chinese Simplified 1001156980-B	Chinese Traditional 1001156979-B	Korean 1001156983-B
54	--	--	--	--	--	--	--	--	--
55	--	--	--	--	--	--	--	--	--
56	--	--	--	--	--	--	--	--	--
57	--	--	--	--	--	--	--	--	--
58	--	--	--	--	--	--	--	--	--
59	--	--	--	--	--	--	--	--	--
60	--	--	--	--	--	--	--	--	--
61	--	--	--	--	--	--	--	--	--
62	1001131269	1001131269	--	--	--	1700584	1700584	--	--
63	1001108493	1001108493	--	1001108493	1001108493	1001108493	1001108493	1001108493	1001108493
64	1706941	1706941	--	1706941	1706941	1706941	1706941	1706941	1706941
65	1703687	1703687	1703687	1703687	1703687	1703687	1703687	1703687	1703687
66	1702265	1703990	1705977	1702617	1703544	1702271	1001116861	1001116862	1703987
67	1705351	1705429	--	1705910	1705905	1705426	1705430	1001116863	1705427
68	--	--	--	--	--	--	--	--	--

**Table 4-2. 600AJ Decal Legend**

<b>Item #</b>	<b>ANSI 1001156890-B</b>	<b>Canadian French 1001156986-B</b>	<b>CE 1001156988-B</b>	<b>Spanish 1001156973-B</b>	<b>Portuguese 1001156975-B</b>	<b>Japanese 1001156977-B</b>	<b>Australian 1001156978-B</b>	<b>Chinese Simplified 1001156982-B</b>	<b>Chinese Traditional 1001156981-B</b>	<b>Korean 1001156984-B</b>
1	--	--	--	--	--	--	--	--	--	--
2	1701499	1701499	1701499	1701499	1701499	1701499	1701499	1701499	1701499	1701499
3	--	--	--	--	--	--	--	--	--	--
4	--	--	--	--	--	--	--	--	--	--
5	1701509	1701509	1701509	1701509	1701509	1701509	1701509	1701509	1701509	1701509
6	1701529	1701529	1701529	1701529	1701529	1701529	1701529	1701529	1701529	1701529
7	--	--	--	--	--	--	--	--	--	--
8	--	--	--	--	--	--	--	--	--	--
9	--	--	--	--	--	--	--	--	--	--
10	1703811	1703811	1703811	1703811	1703811	1703811	1703811	1703811	1703811	1703811
11	1703814	1703814	1703814	1703814	1703814	1703814	1703814	1703814	1703814	1703814
12	1704277	1704277	1704277	1704277	1704277	1704277	1704277	1704277	1704277	1704277
13	1704412	1704412	1704412	1704412	1704412	1704412	1704412	1704412	1704412	1704412
14	--	--	--	--	--	--	1705084	1705084	1705084	1705084
15	--	1705514	--	--	--	--	1705514	1705514	1705514	1705514
16	--	--	--	--	--	--	--	--	--	--
17	3251243	3251243	3251243	3251243	3251243	3251243	--	--	--	3251243

## SECTION 4 - MACHINE OPERATION

**Table 4-2. 600AJ Decal Legend**

Item #	ANSI 1001156890-B	Canadian French 1001156986-B	CE 1001156988-B	Spanish 1001156973-B	Portuguese 1001156975-B	Japanese 1001156977-B	Australian 1001156978-B	Chinese Simplified 1001156982-B	Chinese Traditional 1001156981-B	Korean 1001156984-B
18	--	--	--	--	--	--	--	--	--	--
19	--	--	--	--	--	--	--	--	1001117034	--
20	--	--	--	--	--	--	--	--	1001117035	--
21	--	--	--	--	--	--	--	--	--	--
22	1703953	1703942	--	1703941	1705903	1703944	--	1001116845	1703943	1703945
23	--	--	--	--	--	--	--	--	--	--
24	1702868	1704000	--	1704001	1705967	--	--	1706968	1001116846	1705969
25	1703797	1703924	1705921	1703923	1705895	1703926	1705921	1001116847	1703925	1703927
26	1705336	1705347	1705822	1705917	1705896	1705344	1705822	1001116848	1001116849	1705345
27	1703804	1703948	1701518	1703947	1705898	1703950	1701518	1001116850	1703949	1703951
28	1703805	1703936	1705961	1703935	1705897	1703938	1705961	1703937	1001116851	1703939
29	--	1703984	1705828	1703983	1705902	1703980	1705828	1001116852	1703982	1703981
30	3251813	3251813	--	--	--	--	--	--	--	--
31	--	--	--	--	--	--	--	--	--	--
32	--	--	--	--	--	--	--	--	--	--
33	1001156891	1001156891	1001156891	1001156891	1001156891	1001156891	1001156891	1001156891	1001156891	1001156891
34	--	--	1702631	--	--	1702631	1702631	1702631	1702631	1702631
35	1702819	1702819	1702819	1702819	1702819	1702819	1702819	1702818	1702818	1702819



**Table 4-2. 600AJ Decal Legend**

<b>Item #</b>	<b>ANSI 1001156890-B</b>	<b>Canadian French 1001156986-B</b>	<b>CE 1001156988-B</b>	<b>Spanish 1001156973-B</b>	<b>Portuguese 1001156975-B</b>	<b>Japanese 1001156977-B</b>	<b>Australian 1001156978-B</b>	<b>Chinese Simplified 1001156982-B</b>	<b>Chinese Traditional 1001156981-B</b>	<b>Korean 1001156984-B</b>
36	1001121814	1001121816	1705978	1001121818	1001121655	1001121821	1705978	1001121825	1001121823	1001121921
37	1001121801	1001121803	1705978	1001121805	1001121656	1001121808	1705978	1001121812	1001121810	1001121918
38	--	--	--	--	--	--	--	--	--	--
39	1704885	1704885	1704885	1704885	1704885	1704885	1704885	1704885	1704885	1704885
40	--	1706948	--	--	1706948	--	--	--	--	--
41	--	--	--	--	--	--	--	--	--	--
42	--	--	--	--	--	--	--	--	--	--
43	--	--	--	--	--	--	--	--	--	--
44	--	--	--	--	--	--	--	--	--	--
45	--	--	--	--	--	--	--	--	--	--
46	--	--	--	--	--	--	--	--	--	--
47	--	--	--	--	--	--	--	--	--	--
48	--	--	--	--	--	--	--	--	--	--
49	--	--	--	--	--	--	--	--	--	--
50	--	--	--	--	--	--	--	--	--	--
51	--	--	--	--	--	--	--	--	--	--
52	--	--	--	--	--	--	--	--	--	--
53	--	--	--	--	--	--	--	--	--	--

## SECTION 4 - MACHINE OPERATION

Table 4-2. 600AJ Decal Legend

Item #	ANSI 1001156890-B	Canadian French 1001156986-B	CE 1001156988-B	Spanish 1001156973-B	Portuguese 1001156975-B	Japanese 1001156977-B	Australian 1001156978-B	Chinese Simplified 1001156982-B	Chinese Traditional 1001156981-B	Korean 1001156984-B
54	--	--	--	--	--	--	--	--	--	--
55	--	--	--	--	--	--	--	--	--	--
56	--	--	--	--	--	--	--	--	--	--
57	--	--	--	--	--	--	--	--	--	--
58	--	--	--	--	--	--	--	--	--	--
59	--	--	--	--	--	--	--	--	--	--
60	--	--	--	--	--	--	--	--	--	--
61	--	--	--	--	--	--	--	--	--	--
62	1001131269	1001131269	--	1702573	--	--	--	--	--	1001131269
63	1001108493	1001108493	--	1001108493	1001108493	1001108493	--	1001108493	1001108493	1001108493
64	1706941	1706941	--	1706941	1706941	1706941	--	1706941	1706941	1706941
65	1703687	1703687	1703687	1703687	1703687	1703687	1703687	1703687	1703687	1703687
66	1702265	1703990	1705977	1702617	1703544	1702271	1705977	1001116861	1001116862	1703987
67	1705351	1705429	--	1705910	1705905	1705426	--	1705430	1001116863	1705427
68	--	--	--	--	--	--	1001112551	--	--	--

## SECTION 5. EMERGENCY PROCEDURES

### 5.1 GENERAL

This section explains the steps to be taken in case of an emergency situation while operating.

### 5.2 INCIDENT NOTIFICATION

JLG Industries, Inc. must be notified immediately of any incident involving a JLG product. Even if no injury or property damage is evident, the factory should be contacted by telephone and provided with all necessary details.

In USA:

JLG Phone: 877-JLG-SAFE (554-7233)  
(8am till 4:45pm EST)

Outside USA:

240-420-2661

E-mail:

ProductSafety@JLG.com

Failure to notify the manufacturer of an incident involving a JLG Industries product within 48 hours of such an occurrence may void any warranty consideration on that particular machine.

### **NOTICE**

**FOLLOWING ANY ACCIDENT, THOROUGHLY INSPECT THE MACHINE AND TEST ALL FUNCTIONS FIRST FROM THE GROUND CONTROLS, THEN FROM THE PLATFORM CONTROLS. DO NOT LIFT ABOVE 3 M (10 FT.) UNTIL YOU ARE SURE THAT ALL DAMAGE HAS BEEN REPAIRED, IF REQUIRED, AND THAT ALL CONTROLS ARE OPERATING CORRECTLY.**

### 5.3 EMERGENCY OPERATION

#### Operator Unable to Control Machine

IF THE PLATFORM OPERATOR IS PINNED, TRAPPED OR UNABLE TO OPERATE OR CONTROL MACHINE:

1. Other personnel should operate the machine from ground controls only as required.
2. Other qualified personnel on the platform may use the platform controls. DO NOT CONTINUE OPERATION IF CONTROLS DO NOT FUNCTION PROPERLY.
3. Cranes, forklift trucks or other equipment can be used to remove platform occupants and stabilize motion of the machine.

## **SECTION 5 - EMERGENCY PROCEDURES**

---

### **Platform or Boom Caught Overhead**

If the platform or boom becomes jammed or snagged in overhead structures or equipment, rescue platform occupants prior to freeing the machine.

### **5.4 EMERGENCY TOWING PROCEDURES**

Towing this machine is prohibited, unless properly equipped. However, provisions for moving the machine have been incorporated. For specific procedures, refer to Section 4.

## SECTION 6. GENERAL SPECIFICATIONS & OPERATOR MAINTENANCE

### 6.1 INTRODUCTION

This section of the manual provides additional necessary information to the operator for proper operation and maintenance of this machine.

The maintenance portion of this section is intended as information to assist the machine operator to perform daily maintenance tasks only, and does not replace the more thorough Preventive Maintenance and Inspection Schedule included in the Service and Maintenance Manual.

#### Other Publications Available:

- Service and Maintenance Manual - Global Spec  
(s/n 0300177361 to Present).....3121616
- Illustrated Parts Manual - Global Spec  
(s/n 0300177361 to Present).....3121617

### 6.2 OPERATING SPECIFICATIONS

**Table 6-1. Operating Specifications**

Maximum Work Load (Capacity) - ANSI Unrestricted: Restricted:	500lb (227 kg) 1000lb (454 kg)
Maximum Work Load (Capacity) - CE & Australia Unrestricted: Restricted:	500lb (230 kg) 1000lb (450 kg)
Maximum Travel Grade (Gradeability) 2WD 4WD	30% 45%
Maximum Travel Grade (Side Slope)	5°
Turning Radius - (outside) 2WS 4WS	17 ft. 8 in. (5.38 m) 11 ft. 8 in. (3.56 m)
Turning Radius - (outside) narrow chassis 2WS 4WS	16 ft. 6 in. (5.03 m) 11 ft. 2 in. (3.4 m)
Turning Radius - (inside) 2WS 4WS	11 ft. 5 in. (3.48 m) 5 ft. 6 in. (1.68 m)

## SECTION 6 - GENERAL SPECIFICATIONS & OPERATOR MAINTENANCE

**Table 6-1. Operating Specifications**

Turning Radius - (inside) narrow chassis 2WS 4WS	12 ft. 2 in. (3.71 m) 5 ft. 7 in. (1.7 m)
Maximum Tire Load:	11,700 lbs. (5307 kg)
Ground Bearing Pressure 600A 600AJ 600A - narrow chassis 600AJ - narrow chassis	77 psi (5.5 kg/cm <sup>2</sup> ) 77 psi (5.5 kg/cm <sup>2</sup> ) 94 psi (6.6 kg/cm <sup>2</sup> ) 94 psi (6.6 kg/cm <sup>2</sup> )
Maximum Drive Speed	4.25 MPH (6.84 Km/hr.)
Gross Machine Weight --600A (Approximate) 2WS 4WS Narrow Chassis	21,640 lbs. (9,816 kg) 22,040 lbs. (9,997 kg) 23,900 lbs. (10,841 kg)
Gross Machine Weight --600AJ (Approximate) 2WS 4WS Narrow Chassis	22,240 lbs. (10,088 kg) 22,740 lbs. (10,315 kg) 24,000 lbs. (10,886 kg)

## Dimensional Data

**Table 6-2. Dimensional Data**

Machine Height (Stowed) 600A 600AJ	8 ft. 4 in. (2.54 m) 8 ft. 5 in. (2.57 m)
Machine Length (Stowed) 600A 600AJ	26 ft. 5 in. (8.05 m) 29 ft. (8.80 m)
Machine Width (by tire size) 355/55D-625 41/18LLx22.5X625 (turf)	98 in. (2.49 m) 100 in. (2.54 m)
Wheelbase	8 ft. 2 in. (2.49 m)
Ground Clearance	11.7 in. (0.29 m)
Platform Height 600A 600AJ	60 ft. 5 in. (18.42 m) 60 ft. 7 in. (18.47 m)
Horizontal Reach 600A 600AJ	39 ft. 7 in. (12.07 m) 39 ft. 9 in. (12.10 m)
Tail Swing	0 in. (0 m)

**Capacities**

**Table 6-3. Capacities**

Fuel Tank	30 Gallons (113.6 L)
Hydraulic Oil Tank	30.6 Gallons (115.8 L)
Hydraulic System (Including Tank)	40 Gallons (151.4 L)
Torque Hub, Drive *	20 ounces (0.6 L)
Engine Crankcase Deutz D2011L04 Deutz TD 2.9L GM	11 quarts (10.5 L) 2.4 Gallon (8.9L) w/Filter 4.5 qts. (4.25L) w/Filter
*Torque hubs should be one half full of lubricant.	

**Engine Data**

**Table 6-4. Deutz D2011L04 Specifications**

Fuel	Diesel
Oil Capacity	
Cooling System	5 Quarts (4.5 L)
Crankcase	11 Quarts (10.5 L) w/Filter
Total Capacity	16 Quarts (15 L)
Idle RPM	1000
Low RPM	1800
High RPM	2500
Alternator	60 Amp, belt drive
Battery	950 Cold Cranking Amps, 205 Minutes Reserve Capacity, 12VDC
Fuel Consumption	0.65 GPH (2.46 lph)
Horsepower	49

## SECTION 6 - GENERAL SPECIFICATIONS & OPERATOR MAINTENANCE

**Table 6-5. Deutz TD 2.9 Specifications**

Fuel	Ultra Low Sulfur Diesel (15 ppm)
Output	67 hp (50 kW)
Torque	173 ft.lbs. (234 Nm) @ 1800rpm
Oil Capacity (Crankcase)	2.4 Gallon (8.9 L) w/Filter
Cooling System	3.3 Gallon (12.5 L)
Low RPM	1200 ± 50 rpm
High RPM	2600 ± 50 rpm
Alternator	95 Amp
Fuel Consumption	0.65 GPH (2.48 lph)

**Table 6-6. GM 3.0L**

Fuel	Gasoline or Gasoline/LP Gas
No. of Cylinders	4
BHP	
Gasoline	83 hp @ 3000 rpm
LP	75 hp @ 3000 rpm
Bore	4.0 in. (101.6 mm)
Stroke	3.6 in. (91.44 mm)
Displacement	181 cu.in. (3.0 L, 2966 cc)
Oil Capacity w/filter	4.5 qts. (4.25 L)
Minimum Oil Pressure	
at idle	6 psi (0.4 Bar) @ 1000 rpm
Hot	18 psi (1.2 Bar) @ 2000 rpm
Compression Ratio	9.2:1
Firing Order	1-3-4-2
Max. RPM	2800
Fuel Consumption	
Gas	1.27 gph (4.81 lph)
LP	7.25 Lb./h (3.29 Kg/h)



**Tires**

**Table 6-7. Tire Specifications**

Size	IN355/55D 625	IN355/55D 625	14x17.5
Load Range	G	G	*
Ply Rating	14	14	N/A
Tire Pressure	90 PSI (6 Bar)	Foam-Filled	Air-Boss

\* Load Capacity - 11,700lb. (5307 kg) - Static

Size	41/18LLx22.5	36x12-20FA
Load Range*	G	**
Ply Rating	--	N/A
Tire Pressure	70 PSI (5 Bar)	Solid-Boss

\* Load Capacity - 15,500 lb. (5443 kg) - Static

\*\* Load Capacity - 11,800 lb. (4404 kg) - Static

**Hydraulic Oil**

**Table 6-8. Hydraulic Oil**

HYDRAULIC SYSTEM OPERATING TEMPERATURE RANGE	SAE VISCOSITY GRADE
+0° to +180°F (-18°C to +83°C)	10W
+0°F to +210°F (-18°C to +99°C)	10W-20, 10W-30
+50°F to +210°F (+10°C to +210°C)	20W-20

**NOTE:** Hydraulic oils must have anti-wear qualities at least to API Service Classification GL-3, and sufficient chemical stability for mobile hydraulic system service. JLG Industries recommends Mobilfluid 424 hydraulic oil, which has an SAE viscosity index of 152.

**NOTE:** When temperatures remain below 20° F (-7 degrees C), JLG Industries recommends the use of Mobil DTE 13M.

Aside from JLG recommendations, it is not advisable to mix oils of different brands or types, as they may not contain the same required additives or be of comparable viscosities. If use of hydraulic oil other than Mobilfluid 424 is desired, contact JLG Industries for proper recommendations.

## SECTION 6 - GENERAL SPECIFICATIONS & OPERATOR MAINTENANCE

**Table 6-9. Mobilfluid 424 Specs**

SAE Grade	10W30
Gravity, API	29.0
Density, Lb/Gal. 60°F	7.35
Pour Point, Max	-46°F (-43°C)
Flash Point, Min.	442°F (228°C)
<b>Viscosity</b>	
Brookfield, cP at -18°C	2700
at 40°C	55 cSt
at 100°C	9.3 cSt
Viscosity Index	152

**Table 6-10. Mobil DTE 13M Specs**

ISO Viscosity Grade	#32
Specific Gravity	0.877
Pour Point, Max	-40°F (-40°C)
Flash Point, Min.	330°F (166°C)
<b>Viscosity</b>	
at 40°C	33cSt
at 100°C	6.6 cSt
at 100°F	169 SUS
at 210°F	48 SUS
cp at -20°F	6,200
Viscosity Index	140

**SECTION 6 - GENERAL SPECIFICATIONS & OPERATOR MAINTENANCE**

**Table 6-11. Mobil EAL H 46 Specs**

Type	Synthetic Biodegradable
ISO Viscosity Grade	46
Specific Gravity	.910
Pour Point	-44°F (-42°C)
Flash Point	500°F (260°C)
Operating Temp.	0 to 180°F (-17 to 162°C)
Weight	7.64 lb. per gal. (0.9 kg per liter)
<b>Viscosity</b>	
at 40°C	45 cSt
at 100°C	8.0 cSt
Viscosity Index	153

**Table 6-12. Exxon Univis HVI 26 Specs**

Specific Gravity	32.1
Pour Point	-76°F (-60°C)
Flash Point	217°F (103°C)
<b>Viscosity</b>	
at 40°C	25.8 cSt
at 100°C	9.3 cSt
Viscosity Index	376
<b>NOTE:</b> Mobil/Exxon recommends that this oil be checked on a yearly basis for viscosity.	

## SECTION 6 - GENERAL SPECIFICATIONS & OPERATOR MAINTENANCE

**Table 6-13. Mobil EAL 224H Specs**

Type	Synthetic Biodegradable
ISO Viscosity Grade	32/46
Specific Gravity	.922
Pour Point, Max	-25°F (-32°C)
Flash Point, Min.	428°F (220°C)
Operating Temp.	0 to 180°F (-17 to 162°C)
Weight	7.64 lb. per gal. (0.9 kg per liter)
<b>Viscosity</b>	
at 40°C	37 cSt
at 100°C	8.4 cSt
Viscosity Index	213
<b>NOTE:</b> Must be stored above 32°F (14°C)	

**Table 6-14. Quintolubric 888-46**

Density	0.91 @ 15°C (59°F)
Pour Point	<-20°C (<-4°F)
Flash Point	275°C (527°F)
Fire Point	325°C (617°F)
Autoignition Temperature	450°C (842°F)
<b>Viscosity</b>	
at 0°C (32°F)	360 cSt
at 20°C (68°F)	102 cSt
at 40°C (104°F)	46 cSt
at 100°C (212°F)	10 cSt
Viscosity Index	220

**Critical Stability Weights**



**DO NOT REPLACE ITEMS CRITICAL TO STABILITY WITH ITEMS OF DIFFERENT WEIGHT OR SPECIFICATION (FOR EXAMPLE: BATTERIES, FILLED TIRES, COUNTERWEIGHT, ENGINE & PLATFORM) DO NOT MODIFY UNIT IN ANY WAY TO AFFECT STABILITY.**

**Table 6-15. Critical Stability Weights**

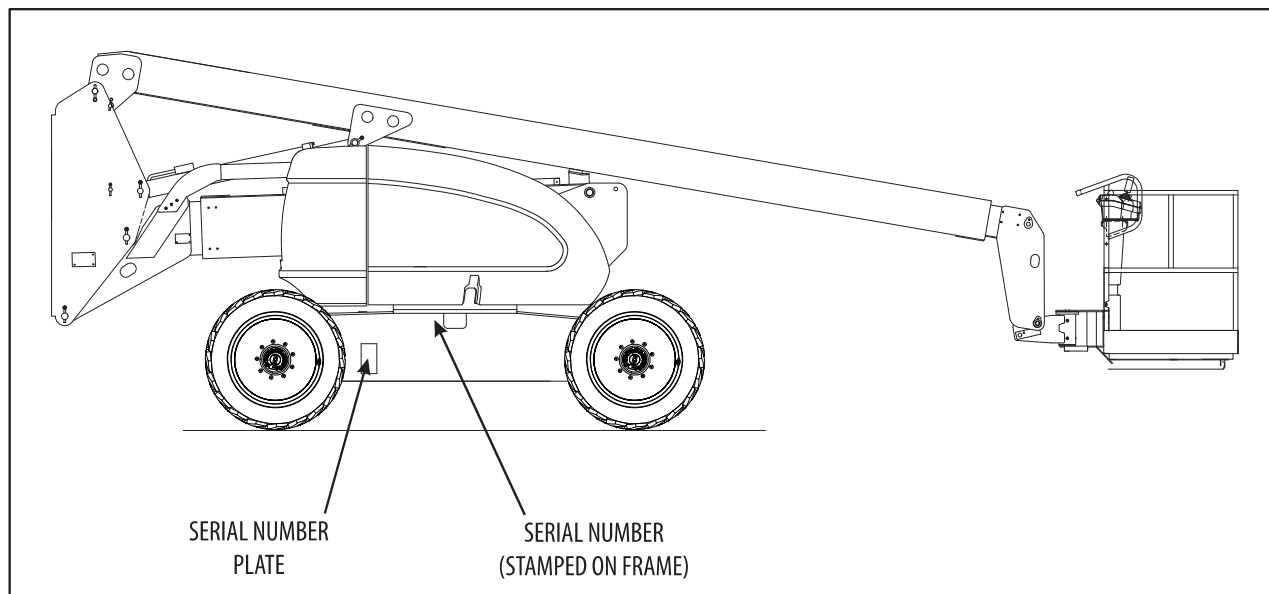
		LB.	KG.
Tire and Wheel (standard Pneumatic)	355/55D345	235	107
Tire and Wheel (standard Foam-Filled)	355/55D345	440	200
Engine	Deutz D2011	1222	554
	Deutz TD2.9L	1250	567
	GM	1070	486
Counterweight	600A	5400	2449
	600AJ	6100	2767
	Narrow Frame	8050	3651
	600A w/Soft Touch	6100	2767

**Table 6-15. Critical Stability Weights**

Platform	30x48	151	68
	30x60	165	75
	36x72	199	90
	36x96	230	105

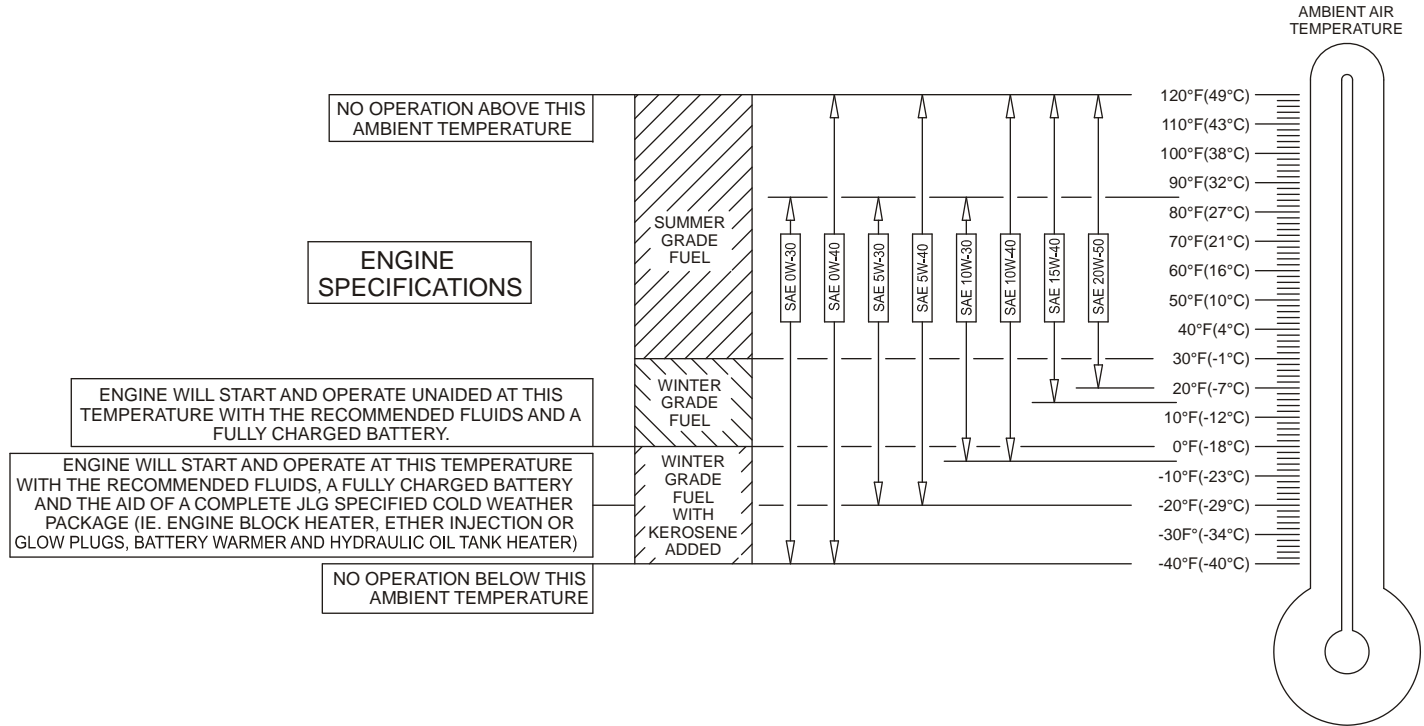
### Serial Number Locations

A serial number plate is affixed to the left rear side of the frame. If the serial number plate is damaged or missing, the machine serial number is stamped on the left side of the frame.



**Figure 6-1. Serial Number Locations**

## SECTION 6 - GENERAL SPECIFICATIONS & OPERATOR MAINTENANCE



**Figure 6-2. Engine Operating Temperature Specifications - Deutz - Sheet 1 of 2**

# SECTION 6 - GENERAL SPECIFICATIONS & OPERATOR MAINTENANCE

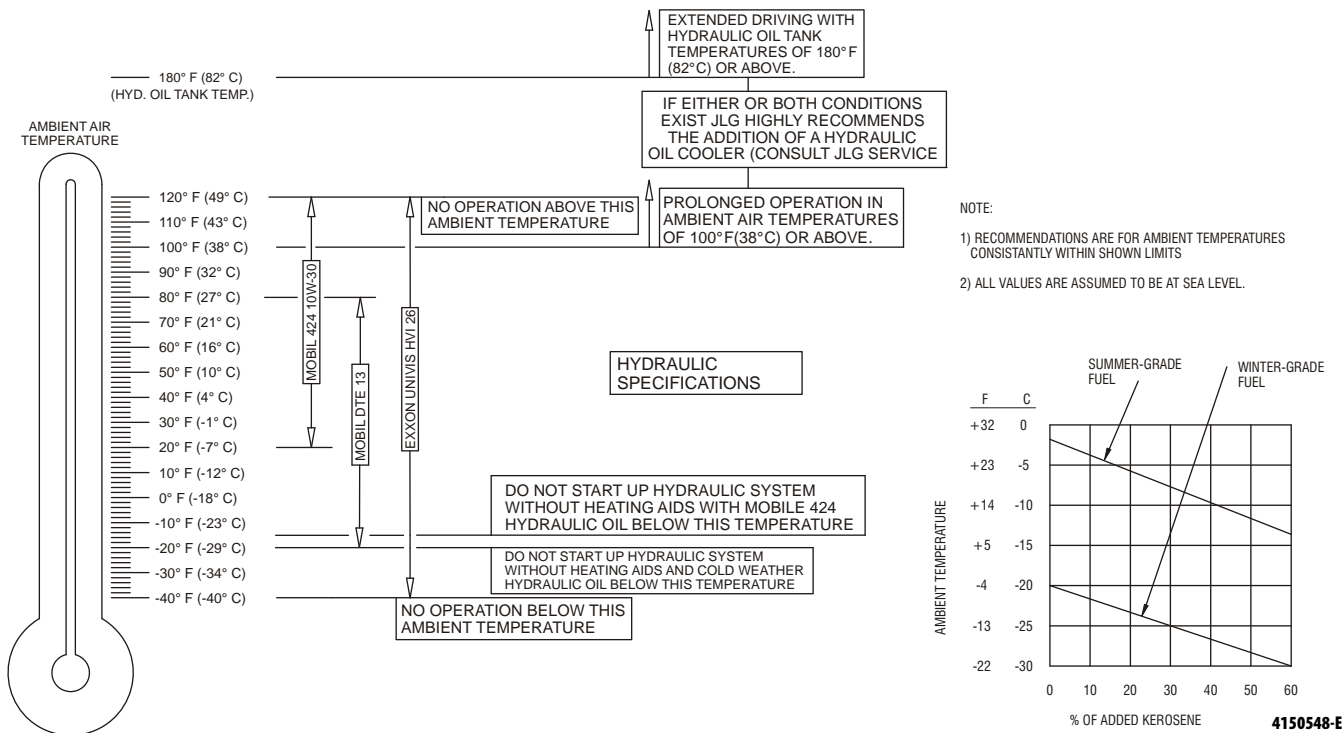
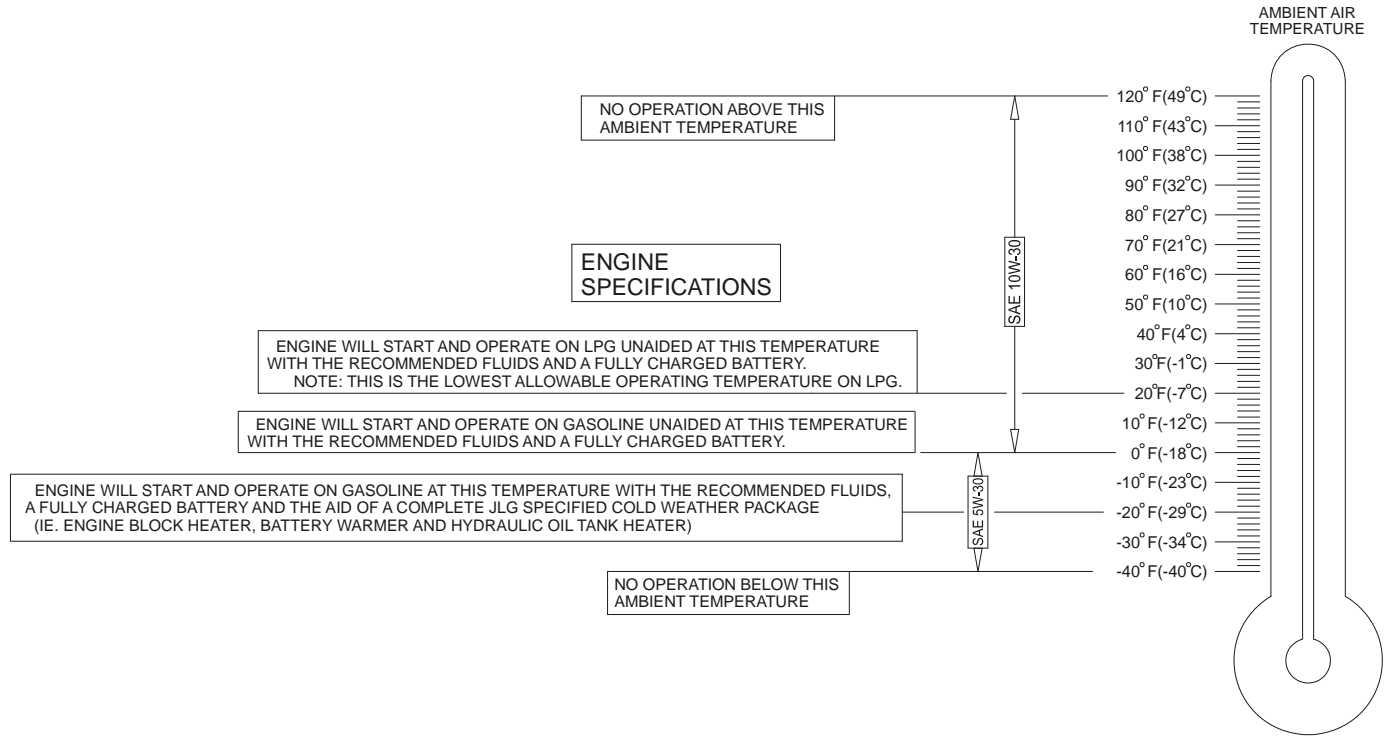


Figure 6-3. Engine Operating Temperature Specifications - Deutz - Sheet 2 of 2

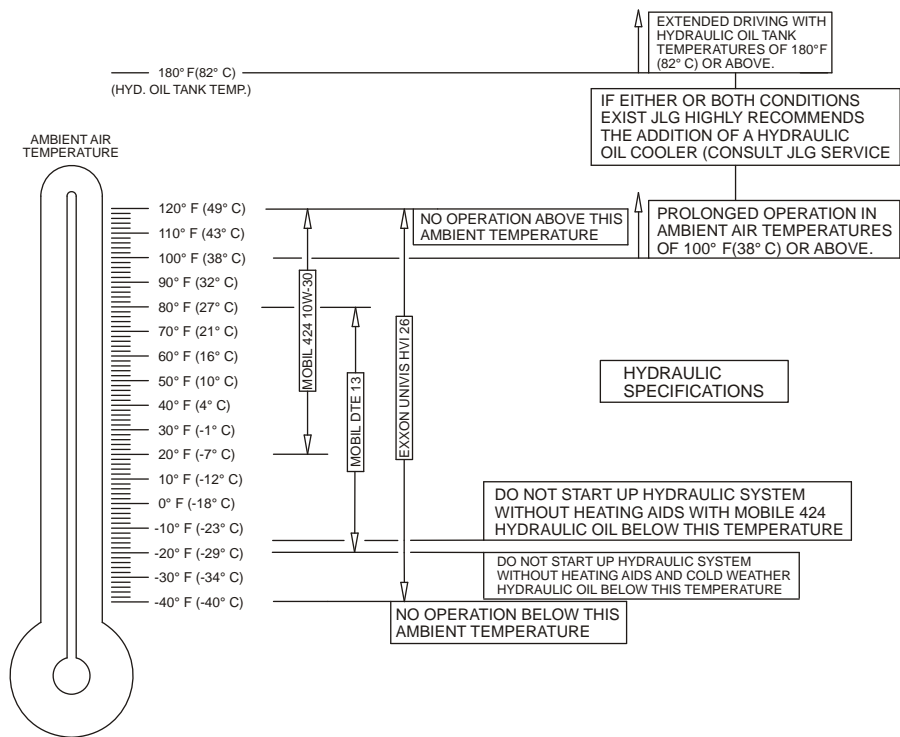


## SECTION 6 - GENERAL SPECIFICATIONS & OPERATOR MAINTENANCE



**Figure 6-4. Engine Operating Temperature Specifications - GM - Sheet 1 of 2**

## SECTION 6 - GENERAL SPECIFICATIONS & OPERATOR MAINTENANCE

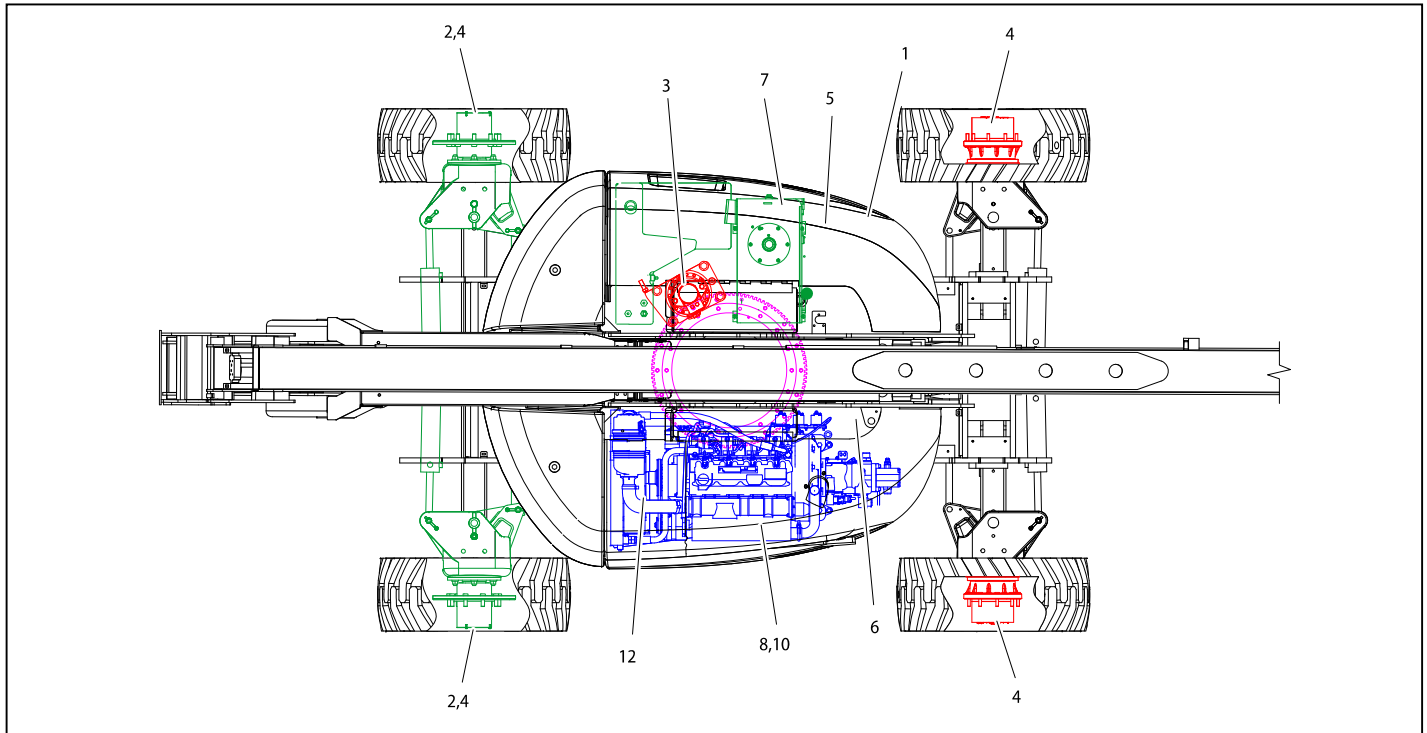


NOTE:

- 1) RECOMMENDATIONS ARE FOR AMBIENT TEMPERATURES CONSISTENTLY WITHIN SHOWN LIMITS
- 2) ALL VALUES ARE ASSUMED TO BE AT SEA LEVEL.

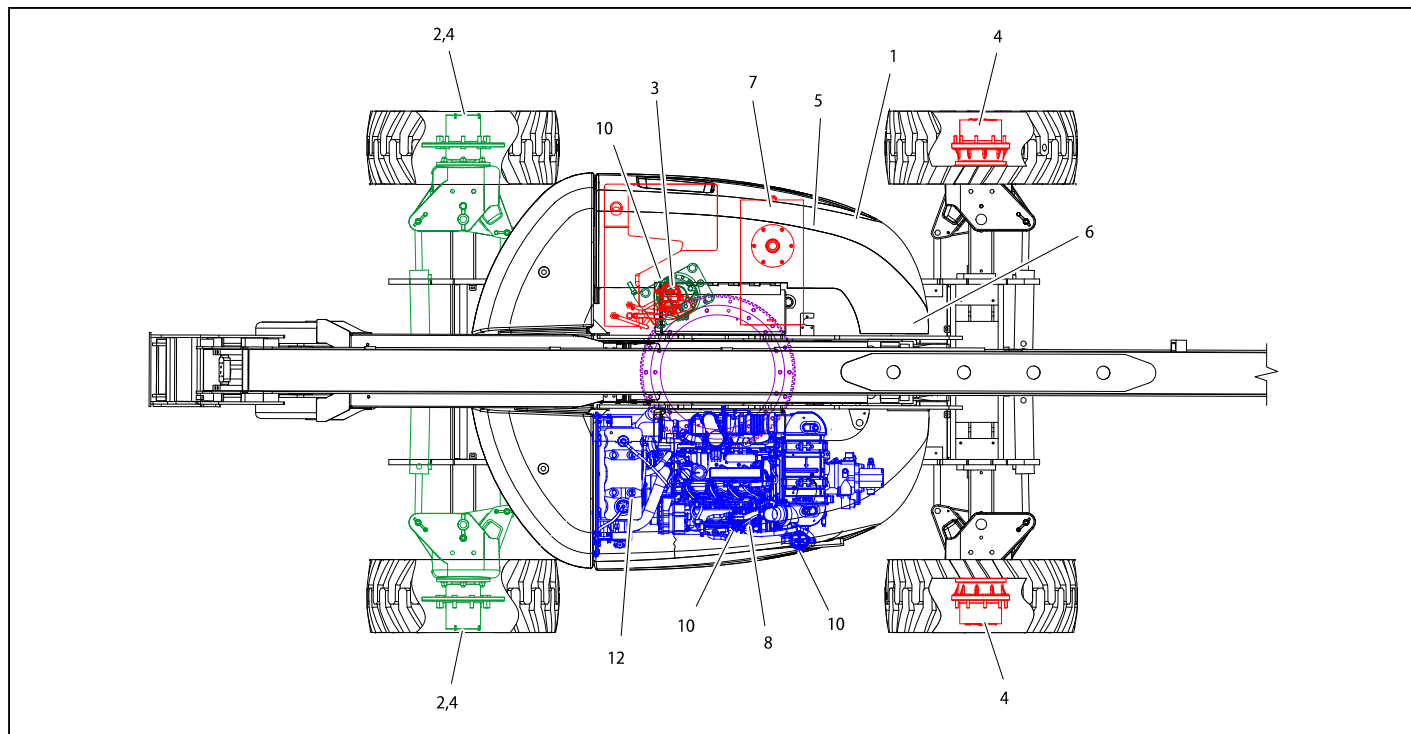
Figure 6-5. Engine Operating Temperature Specifications - GM - Sheet 2 of 2

4150548-E

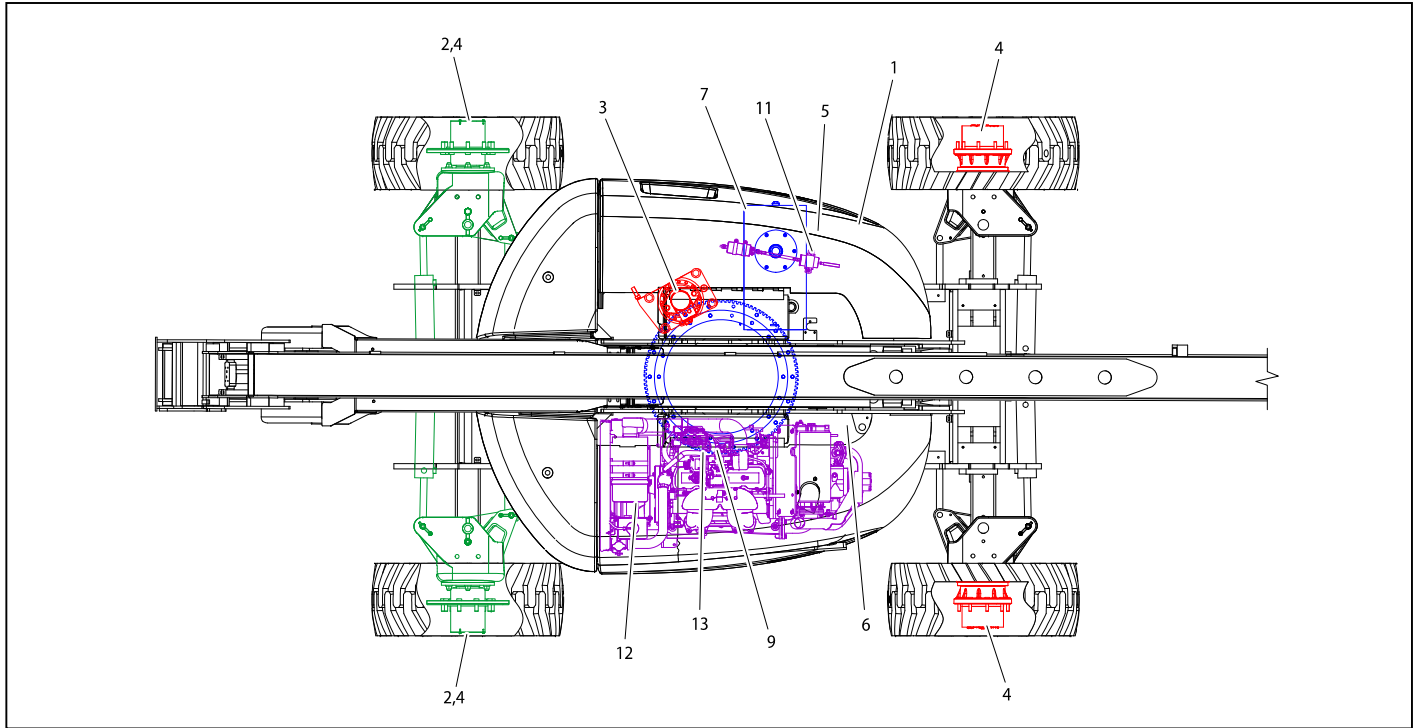


**Figure 6-6. Operator Maintenance & Lubrication Diagram - Deutz D2011L04**

## SECTION 6 - GENERAL SPECIFICATIONS & OPERATOR MAINTENANCE



**Figure 6-7. Operator Maintenance & Lubrication Diagram - Deutz TD2.9**



**Figure 6-8. Operator Maintenance & Lubrication Diagram - GM 3.0L**

## SECTION 6 - GENERAL SPECIFICATIONS & OPERATOR MAINTENANCE

### 6.3 OPERATOR MAINTENANCE

**NOTE:** The following numbers correspond to those in Figure 6-6., Operator Maintenance & Lubrication Diagram - Deutz D2011L04.

**Table 6-16. Lubrication Specifications**

KEY	SPECIFICATIONS
MPG	Multipurpose Grease having a minimum dripping point of 350°F (177°C). Excellent water resistance and adhesive qualities, and being of extreme pressure type. (Timken OK 40 pounds minimum.)
EPGL	Extreme Pressure Gear Lube (oil) meeting API service classification GL-5 or MIL-Spec MIL-L-2105
HO	Hydraulic Oil. API service classification GL-3, e.g. Mobilfluid 424.
EO	Engine (crankcase) Oil. Gas - API SF, SH, SG class, MIL-L-2104. Diesel - API CC/CD class, MIL-L-2104B/MIL-L-2104C.

#### **NOTICE**

**LUBRICATION INTERVALS ARE BASED ON MACHINE OPERATION UNDER NORMAL CONDITIONS. FOR MACHINES USED IN MULTI-SHIFT OPERATIONS AND/OR EXPOSED TO HOSTILE ENVIRONMENTS OR CONDITIONS, LUBRICATION FREQUENCIES MUST BE INCREASED ACCORDINGLY.**

#### 1. Swing Bearing



Lube Point(s) - 1 Grease Fittings

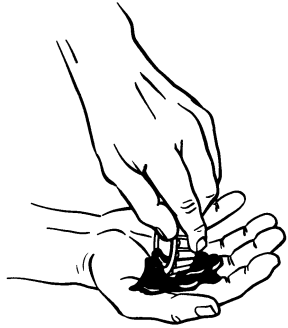
Capacity - A/R

Lube - MPG

Interval - Every 3 months or 150 hrs of operation

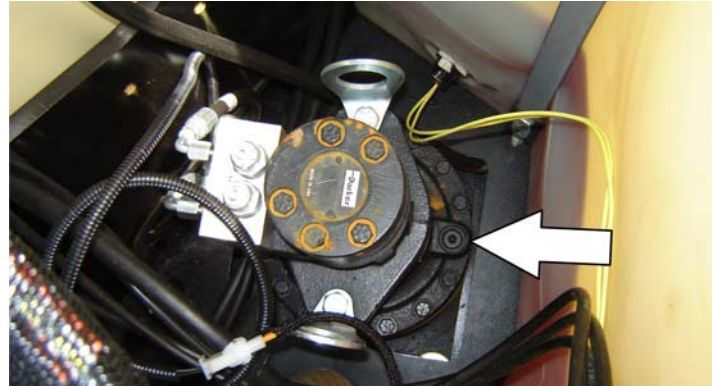
Comments - Remote Access. Apply grease and rotate in 90 degree intervals until bearing is completely lubricated.

**2. Wheel Bearings (If equipped)**



Lube Point(s) - Repack  
Capacity - A/R  
Lube - MPG  
Interval - Every 2 years or 1200 hours of operation

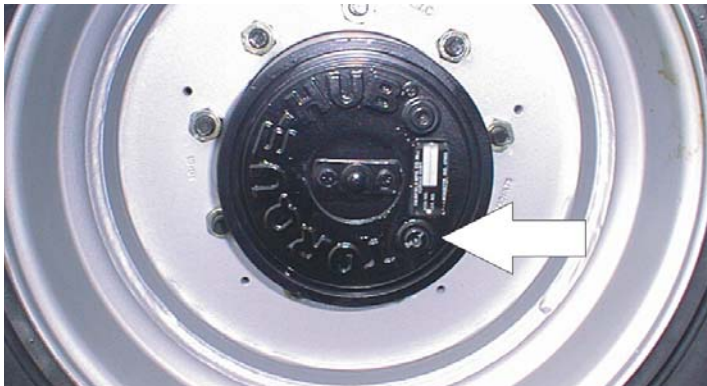
**3. Swing Drive Hub**



Lube Point(s) - Level/Fill Plug  
Capacity - 43 oz. (1.3 L)  
Lube - 90w80 Gear Oil  
Interval - Check level every 3 months or 150 hrs of operation;  
change every 2 years or 1200 hours of operation

## SECTION 6 - GENERAL SPECIFICATIONS & OPERATOR MAINTENANCE

### 4. Wheel Drive Hub



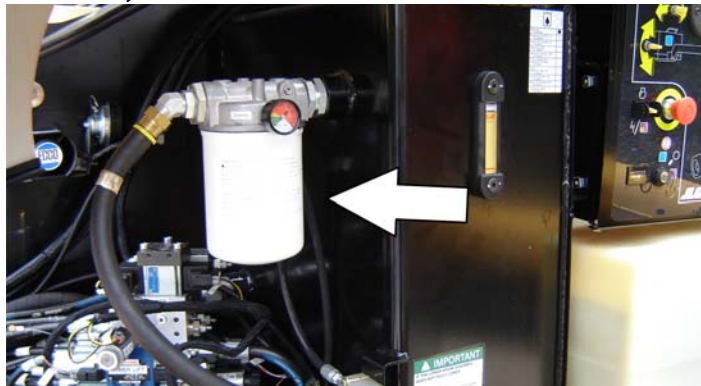
Lube Point(s) - Level/Fill Plug

Capacity - 20 oz. (0.6 L)

Lube - EPGL

Interval - Check level every 3 months or 150 hrs of operation;  
change every 2 years or 1200 hours of operation

### 5. Hydraulic Return Filter



Interval - Change after first 50 hrs. and every 6 months or  
300 hrs. thereafter or as indicated by Condition Indicator.

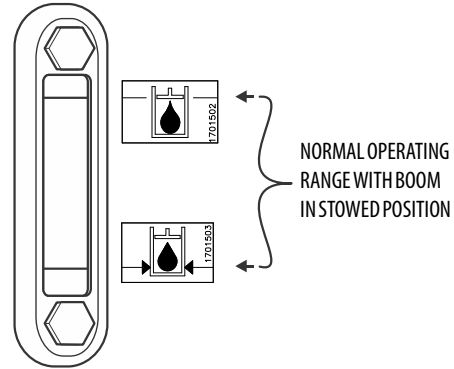


**6. Hydraulic Charge Filter**



Interval - Change after first 50 hrs. and every 6 months or 300 hrs. thereafter or as indicated by Condition Indicator.

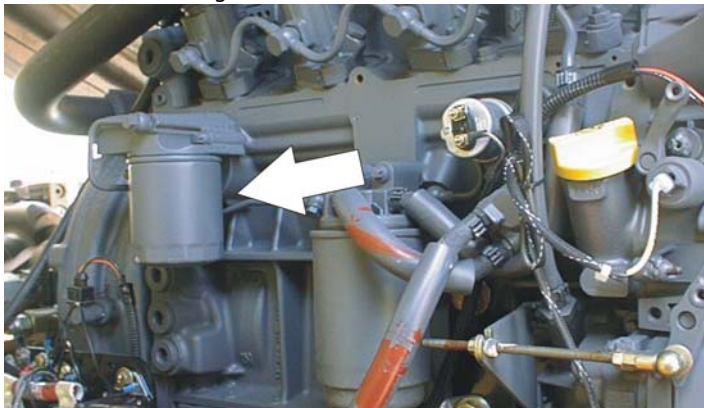
**7. Hydraulic Tank**



Lube Point(s) - Fill Cap  
Capacity - 30.6 gal. (115.8 L) Tank; 40 gal. (151.4 L) System  
Lube - HO  
Interval - Check Level daily; Change every 2 years or 1200 hours of operation.

## SECTION 6 - GENERAL SPECIFICATIONS & OPERATOR MAINTENANCE

### 8. A. Oil Change w/Filter - Deutz 2011



Lube Point(s) - Fill Cap/Spin-on Element  
Capacity - 11 Quarts Crankcase; 5 Quarts Cooler  
Lube - EO  
Interval - Every Year or 1200 hours of operation  
Comments - Check level daily/Change in accordance with engine manual. Refer to Figure 6-9., Deutz 2011 Engine Dipstick.

### B. Oil Change w/Filter - Deutz TD2.9



Lube Point(s) - Fill Cap/Spin-on Element  
Capacity - 9.6 Quarts (9.0 L)  
Lube - EO  
Interval - Every Year or 600 hours of operation  
Comments - Check level daily/Change in accordance with engine manual.

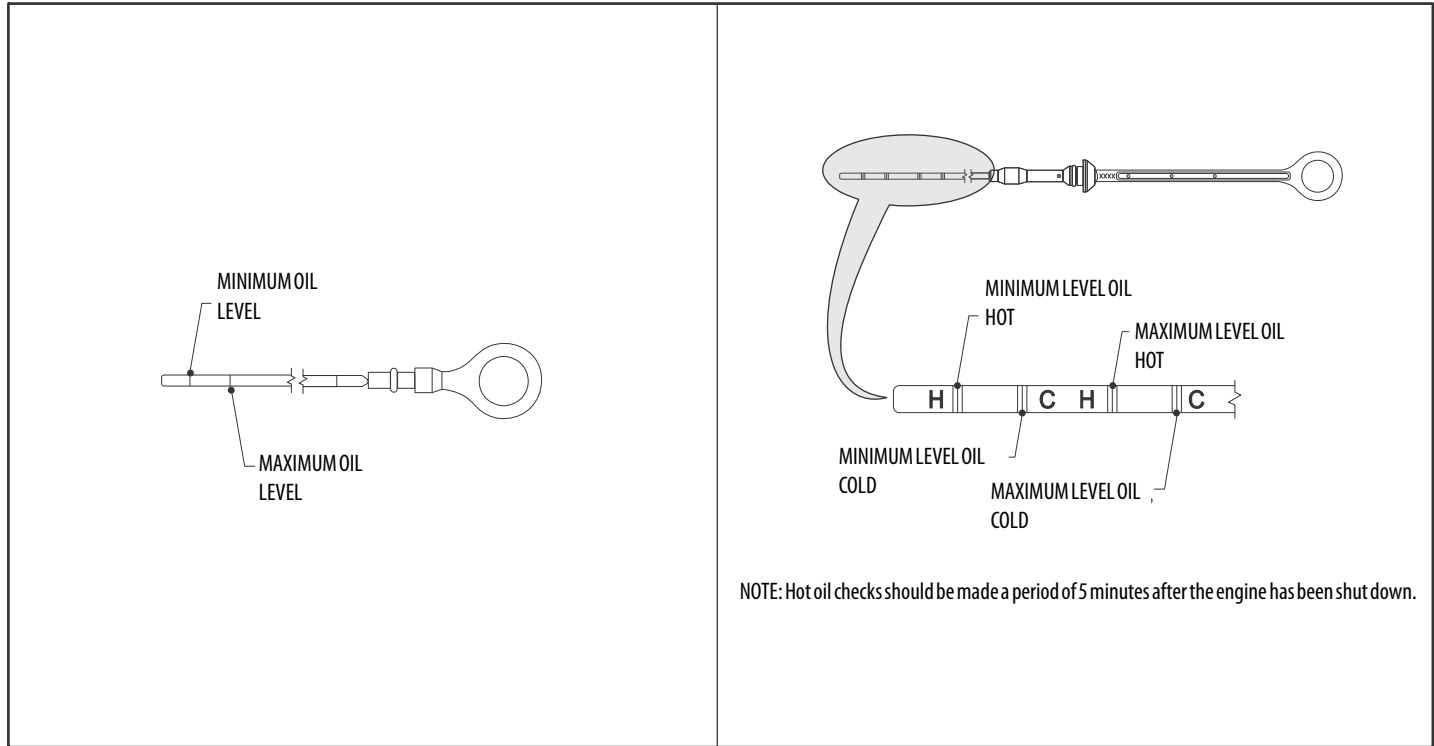


Figure 6-9. Deutz 2011 Engine Dipstick

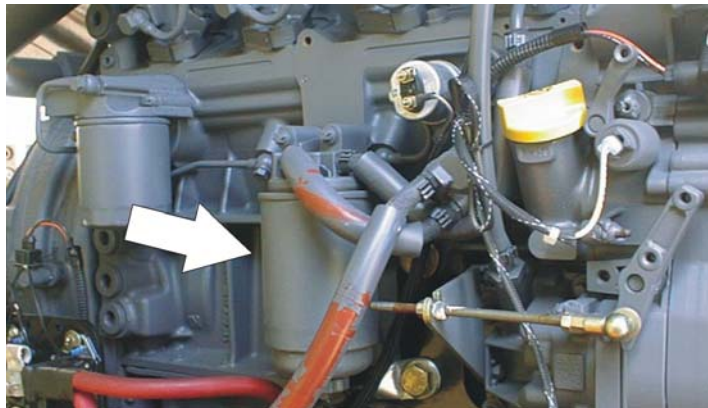
## SECTION 6 - GENERAL SPECIFICATIONS & OPERATOR MAINTENANCE

### 9. Oil Change w/Filter - GM



Lube Point(s) - Fill Cap/Spin-on Element  
Capacity - 4.5 qt. (4.25 L) w/filter  
Lube - EO  
Interval - 3 Months or 150 hours of operation  
Comments - Check level daily/Change in accordance with engine manual.

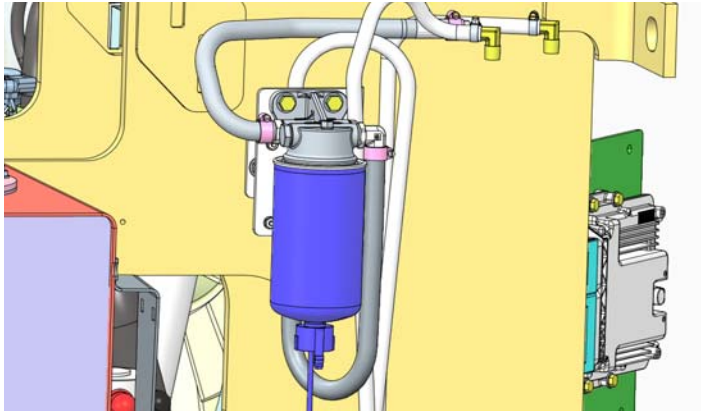
### 10. A. Fuel Filter - Deutz



On Engine:  
Lube Point(s) - Replaceable Element  
Interval - Change in accordance with engine manual

## SECTION 6 - GENERAL SPECIFICATIONS & OPERATOR MAINTENANCE

B. Fuel Filter - Deutz TD2.9 (On Turntable)



Lube Point(s) - Replaceable Element  
Interval - Change in accordance with engine manual

C. Fuel Filter - Deutz TD2.9 (On Engine)



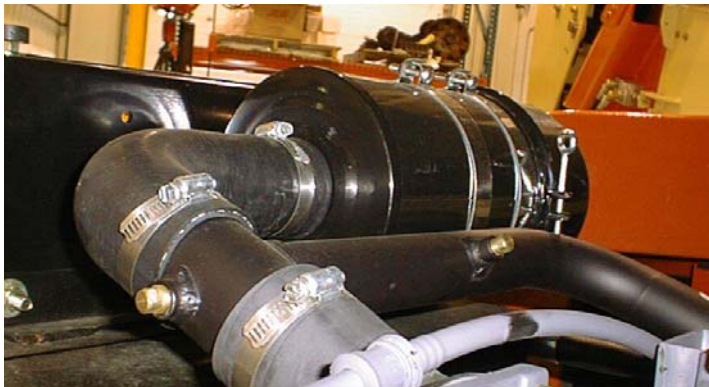
Lube Point(s) - Replaceable Element  
Interval - Change in accordance with engine manual

### 11. Fuel Filter (Gasoline) - GM

Lube Point(s) - Replaceable Element  
Interval - Every 6 months or 300 hours of operation

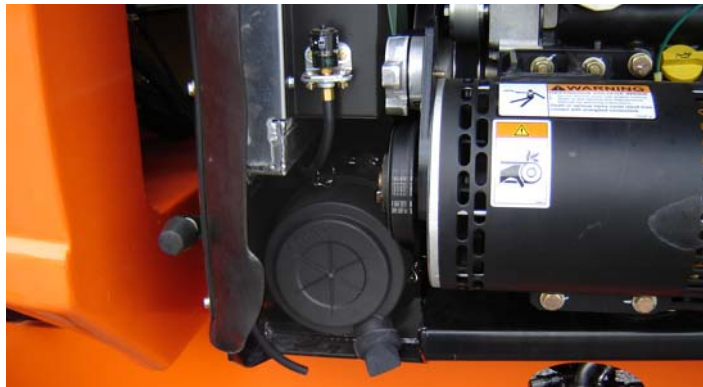
## SECTION 6 - GENERAL SPECIFICATIONS & OPERATOR MAINTENANCE

### 12. A. Air Filter (Deutz 2011 and GM)



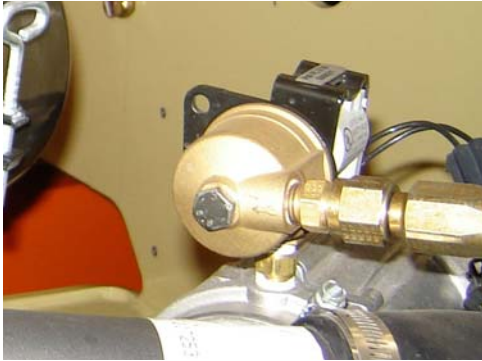
Lube Point(s) - Replaceable Element  
Interval - Every 6 months or 300 hours of operation or as indicated by the condition indicator

### B. Air Filter (Deutz TD 2.9)



Lube Point(s) - Replaceable Element  
Interval - Every 6 months or 300 hours of operation or as indicated by the condition indicator

### 13. Fuel Filter (Propane) - GM Engine



Interval - 3 Months or 150 hours of operation

Comments - Replace filter. Refer to Section 6.6, Propane Fuel Filter Replacement

## 6.4 TIRES & WHEELS

### Tire Inflation

The air pressure for pneumatic tires must be equal to the air pressure that is stenciled on the side of the JLG product or rim decal for safe and proper operational characteristics.

### Tire Damage

For pneumatic tires, JLG Industries, Inc. recommends that when any cut, rip, or tear is discovered that exposes sidewall or tread area cords in the tire, measures must be taken to remove the JLG product from service immediately. Arrangements must be made for replacement of the tire or tire assembly.

For polyurethane foam filled tires, JLG Industries, Inc. recommends that when any of the following are discovered, measures must be taken to remove the JLG product from service immediately and arrangements must be made for replacement of the tire or tire assembly.

- a smooth, even cut through the cord plies which exceeds 3 inches (7.5 cm) in total length
- any tears or rips (ragged edges) in the cord plies which exceeds 1 inch (2.5 cm) in any direction
- any punctures which exceed 1 inch in diameter



- any damage to the bead area cords of the tire

If a tire is damaged but is within the above noted criteria, the tire must be inspected on a daily basis to insure the damage has not propagated beyond the allowable criteria.

### Tire Replacement

JLG recommends a replacement tire be the same size, ply and brand as originally installed on the machine. Please refer to the JLG Parts Manual for the part number of the approved tires for a particular machine model. If not using a JLG approved replacement tire, we recommend that replacement tires have the following characteristics:

- Equal or greater ply/load rating and size of original
- Tire tread contact width equal or greater than original
- Wheel diameter, width, and offset dimensions equal to the original
- Approved for the application by the tire manufacturer (including inflation pressure and maximum tire load)

Unless specifically approved by JLG Industries Inc. do not replace a foam filled or ballast filled tire assembly with a pneumatic tire. When selecting and installing a replacement tire, ensure that all tires are inflated to the pressure recommended by JLG. Due to size variations between tire brands, both tires on the same axle should be the same.

### Wheel Replacement

The rims installed on each product model have been designed for stability requirements which consist of track width, tire pressure, and load capacity. Size changes such as rim width, center piece location, larger or smaller diameter, etc., without written factory recommendations, may result in an unsafe condition regarding stability.

### Wheel Installation

It is extremely important to apply and maintain proper wheel mounting torque.



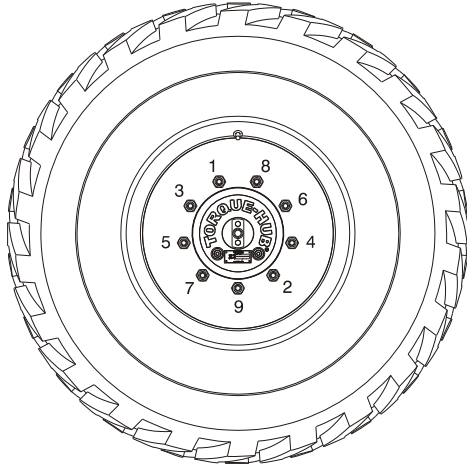
**WHEEL NUTS MUST BE INSTALLED AND MAINTAINED AT THE PROPER TORQUE TO PREVENT LOOSE WHEELS, BROKEN STUDS, AND POSSIBLE DANGEROUS SEPARATION OF WHEEL FROM THE AXLE. BE SURE TO USE ONLY THE NUTS MATCHED TO THE CONE ANGLE OF THE WHEEL.**

Tighten the lug nuts to the proper torque to prevent wheels from coming loose. Use a torque wrench to tighten the fasteners. If you do not have a torque wrench, tighten the fasteners with a lug wrench, then immediately have a service garage or dealer tighten the lug nuts to the proper torque. Over-tightening will result in breaking the studs or permanently deforming the mounting stud holes in the wheels. The proper procedure for attaching wheels is as follows:



## SECTION 6 - GENERAL SPECIFICATIONS & OPERATOR MAINTENANCE

1. Start all nuts by hand to prevent cross threading. DO NOT use a lubricant on threads or nuts.
2. Tighten nuts in the following sequence:



3. The tightening of the nuts should be done in stages. Following the recommended sequence, tighten nuts per wheel torque chart.

**Table 6-17. Wheel Torque Chart**

TORQUE SEQUENCE		
1st Stage	2nd Stage	3rd Stage
40 ft. lbs. (55 Nm)	95 ft. lbs. (130 Nm)	170 ft. lbs. (230 Nm)

4. Wheel nuts should be torqued after first 50 hours of operation and after each wheel removal. Check torque every 3 months or 150 hours of operation.

### 6.5 OSCILLATING AXLE LOCKOUT TEST (IF EQUIPPED)

#### **NOTICE**

**LOCKOUT SYSTEM TEST MUST BE PERFORMED QUARTERLY, ANY TIME A SYSTEM COMPONENT IS REPLACED, OR WHEN IMPROPER SYSTEM OPERATION IS SUSPECTED.**

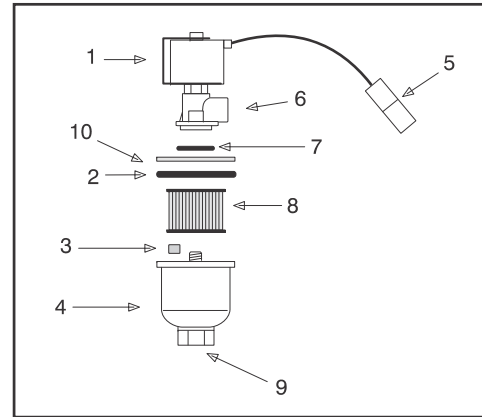
**NOTE:** *Ensure boom is fully retracted, lowered, and centered between drive wheels prior to beginning lockout cylinder test.*

1. Place a 6 inches (15.2 cm) high block with ascension ramp in front of left front wheel.
2. From platform control station, start engine
3. Place the Drive control lever to the forward position and carefully drive machine up ascension ramp until left front wheel is on top of block.
4. Carefully activate Swing control lever and position boom over right side of machine.
5. With boom over right side of machine, place Drive control lever to Reverse and drive machine off of block and ramp.
6. Have an assistant check to see that left front wheel remains locked in position off of ground.
7. Carefully activate Swing control lever and return boom to stowed position (centered between drive wheels). When boom reaches center, stowed position, lockout cylinders should release and allow wheel to rest on ground, it may be necessary to activate Drive to release cylinders.
8. Place the 6 inches (15.2 cm) high block with ascension ramp in front of right front wheel.
9. Place Drive control lever to Forward and carefully drive machine up ascension ramp until right front wheel is on top of block.
10. With boom over left side of machine, place Drive control lever to Reverse and drive machine off of block and ramp.
11. Have an assistant check to see that right front wheel remains locked in position off of ground.
12. Carefully activate Swing control lever and return boom to stowed position (centered between drive wheels). When boom reaches center, stowed position, lockout cylinders should release and allow wheel to rest on ground, it may be necessary activate Drive to release cylinders.
13. If lockout cylinders do not function properly, have qualified personnel correct the malfunction prior to any further operation.

## **6.6 PROPANE FUEL FILTER REPLACEMENT**

### **Removal**

1. Relieve the propane fuel system pressure. Refer to Propane Fuel System Pressure Relief.
2. Disconnect the negative battery cable.
3. Slowly loosen the Filter housing and remove it.
4. Pull the filter housing from the Electric lock off assembly.
5. Remove the filter from the housing.
6. Locate Filter magnet and remove it.
7. Remove and discard the housing seal.



- |                               |                |
|-------------------------------|----------------|
| 1. Electric Lock Off Solenoid | 6. Fuel Outlet |
| 2. Housing Seal               | 7. O-ring      |
| 3. Filter Magnet              | 8. Filter      |
| 4. Filter Housing             | 9. Fuel Inlet  |
| 5. Electrical Connector       | 10. Ring       |

**Figure 6-10. Filter Lock Assembly**

### Installation

#### **NOTICE**

**BE SURE TO REINSTALL THE FILTER MAGNET INTO THE HOUSING BEFORE INSTALLING NEW SEAL**

1. Install the housing seal.
2. Drop the magnet into the bottom of the filter housing.
3. Install the filter into the housing.
4. Install the filter up to the bottom of the electric lock off.
5. Tighten the filter bowl retainer to 106 in lbs (12 Nm).
6. Open manual shut-off valve. Start the vehicle and leak check the propane fuel system at each serviced fitting. Refer to Propane Fuel System Leak Test.

### 6.7 PROPANE FUEL SYSTEM PRESSURE RELIEF

#### **CAUTION**

**THE PROPANE FUEL SYSTEM OPERATES AT PRESSURES UP TO 312 PSI (21.5 BAR). TO MINIMIZE THE RISK OF FIRE AND PERSONAL INJURY, RELIEVE THE PROPANE FUEL SYSTEM PRESSURE (WHERE APPLICABLE) BEFORE SERVICING THE PROPANE FUEL SYSTEM COMPONENTS.**

To relieve propane fuel system pressure:

1. Close the manual shut-off valve on the propane fuel tank.
2. Start and run the vehicle until the engine stalls.
3. Turn the ignition switch OFF.

#### **CAUTION**

**RESIDUAL VAPOR PRESSURE WILL BE PRESENT IN THE FUEL SYSTEM. ENSURE THE WORK AREA IS WELL VENTILATED BEFORE DISCONNECTING ANY FUEL LINE.**

## **6.8 SUPPLEMENTAL INFORMATION**

The following information is provided in accordance with the requirements of the European Machinery Directive 2006/42/EC and is only applicable to CE machines.


For electric powered machines, the equivalent continuous A-Weighted sound pressure level at the work platform is less than 70dB(A)

For combustion engine powered machines, guaranteed Sound Power Level (LWA) per European Directive 2000/14/EC (Noise Emission in the Environment by Equipment for Use Outdoors) based on test methods in accordance with Annex III, Part B, Method 1 and 0 of the directive, is 104 dB.

The vibration total value to which the hand-arm system is subjected does not exceed 2,5 m/s<sup>2</sup>. The highest root mean square value of weighted acceleration to which the whole body is subjected does not exceed 0,5 m/s<sup>2</sup>.

## SECTION 6 - GENERAL SPECIFICATIONS & OPERATOR MAINTENANCE

---

 **NOTES:**

<hr/>	<hr/>
<hr/>	<hr/>
<hr/>	<hr/>
<hr/>	<hr/>
<hr/>	<hr/>
<hr/>	<hr/>
<hr/>	<hr/>
<hr/>	<hr/>
<hr/>	<hr/>
<hr/>	<hr/>
<hr/>	<hr/>
<hr/>	<hr/>
<hr/>	<hr/>
<hr/>	<hr/>
<hr/>	<hr/>
<hr/>	<hr/>
<hr/>	<hr/>
<hr/>	<hr/>
<hr/>	<hr/>
<hr/>	<hr/>
<hr/>	<hr/>
<hr/>	<hr/>
<hr/>	<hr/>

**SECTION 7. INSPECTION AND REPAIR LOG**

Machine Serial Number \_\_\_\_\_

**Table 7-1. Inspection and Repair Log**

<b>Date</b>	<b>Comments</b>

**SECTION 7 - INSPECTION AND REPAIR LOG**

---

**Table 7-1. Inspection and Repair Log**

Date	Comments





## **WARNING:**



**The engine exhaust from this product contains chemicals known to the State of California to cause cancer, birth defects, or other reproductive harm.**

1702961


## **PROPOSITION 65 WARNING**


- **Battery posts, terminals and related accessories contain lead and lead compounds, chemicals known to the State of California to cause cancer and reproductive harm.**
- **Batteries also contain other chemicals known to the State of California to cause cancer.**
- **Wash hands after handling.**



An Oshkosh Corporation Company

**Corporate Office**  
**JLG Industries, Inc.**  
**1 JLG Drive**  
**McConnellsburg PA. 17233-9533**  
**USA**

 **(717) 485-5161**

 **(717) 485-6417**





3121615

## JLG Worldwide Locations

### JLG Industries (Australia)


P.O. Box 5119  
11 Bolwarra Road  
Port Macquarie  
N.S.W. 2444  
Australia


 +61 2 65 811111

 +61 2 65813058

### JLG Latino Americana Ltda.


Rua Eng. Carlos Stevenson,  
80-Suite 71  
13092-310 Campinas-SP  
Brazil


 +55 19 3295 0407

 +55 19 3295 1025

### JLG Industries (UK) Ltd


Bentley House  
Bentley Avenue  
Middleton  
Greater Manchester  
M24 2GP - England


 +44 (0)161 654 1000

 +44 (0)161 654 1001

### JLG France SAS


Z.I. de Baulieu  
47400 Fauillet  
France


 +33 (0)5 53 88 31 70

 +33 (0)5 53 88 31 79

### JLG Deutschland GmbH


Max-Planck-Str. 21  
D - 27721 Ritterhude - Ihlpohl  
Germany


 +49 (0)421 69 350 20

 +49 (0)421 69 350 45

### JLG Equipment Services Ltd.


Rm 1107 Landmark North  
39 Lung Sum Avenue  
Sheung Shui N. T.  
Hong Kong


 (852) 2639 5783

 (852) 2639 5797

### JLG Industries (Italia) s.r.l.


Via Po. 22  
20010 Pregnana Milanese - MI  
Italy


 +39 029 359 5210

 +39 029 359 5845

### Oshkosh-JLG Singapore Technology


Equipment Pte Ltd  
29 Tuas Ave 4,  
Jurong Industrial Estate  
Singapore, 639379


 +65-6591 9030

 +65-6591 9031

### Oshkosh-JLG (Tianjin) Equipment


Technology, Ltd  
Pudong Kerry Parkside  
Room 3705  
1155 Fang Dian Road  
Pudong, Shanghai 201204


 +0086 21 60311575

 +0086 21 60311599

### Plataformas Elevadoras


JLG Iberica, S.L.  
Trapadella, 2  
P.I. Castellbisbal Sur  
08755 Castellbisbal, Barcelona  
Spain


 +34 93 772 4700

 +34 93 771 1762

### JLG Sverige AB

Enkopingsvagen 150  
Box 704  
SE - 176 27 Jarfalla  
Sweden

 +46 (0)850 659 500

 +46 (0)850 659 534